

Musical Mathematics

ON THE ART AND SCIENCE OF ACOUSTIC INSTRUMENTS



Cris Forster

MUSICAL MATHEMATICS

ON THE ART AND SCIENCE OF ACOUSTIC INSTRUMENTS

MUSICAL MATHEMATICS

ON THE ART AND SCIENCE OF ACOUSTIC INSTRUMENTS

Text and Illustrations

by Cris Forster



CHRONICLE BOOKS

SAN FRANCISCO

Copyright © 2010 by Cristiano M.L. Forster

All Rights Reserved. No part of this book may be reproduced in any form without written permission from the publisher.

Library of Congress Cataloging-in-Publication Data available.

ISBN: 978-0-8118-7407-6

Manufactured in the United States.

All royalties from the sale of this book go directly to the Chrysalis Foundation, a public 501(c)3 nonprofit arts and education foundation.

www.chrysalis-foundation.org

Photo Credits:

Will Gullette, Plates 1–12, 14–16.

Norman Seeff, Plate 13.

10 9 8 7 6 5 4 3 2 1

Chronicle Books LLC
680 Second Street
San Francisco, California 94107

www.chroniclebooks.com

In Memory of Page Smith

my enduring teacher

And to Douglas Monsour

our constant friend

I would like to thank the following individuals and foundations for their generous contributions in support of the writing, designing, and typesetting of this work:

Peter Boyer and Terry Gamble-Boyer
The family of Jackson Vanfleet Brown
Thomas Driscoll and Nancy Quinn
Marie-Louise Forster
David Holloway
Jack Jensen and Cathleen O'Brien
James and Deborah Knapp
Ariano Lembi, Aidan and Yuko Fruth-Lembi
Douglas and Jeanne Monsour
Tim O'Shea and Peggy Arent
Fay and Edith Strange
Charles and Helene Wright

Ayrshire Foundation
Chrysalis Foundation

The jewel that we find, we stoop and take't,
Because we see it; but what we do not see
We tread upon, and never think of it.

W. Shakespeare

For more information about
Musical Mathematics: On the Art and Science of Acoustic Instruments
please visit:

www.chrysalis-foundation.org

www.amazon.com

www.chroniclebooks.com

CONTENTS

Foreword by David R. Canright	v
Introduction and Acknowledgments	vii
Tone Notation	ix
List of Symbols	xi
CHAPTER 1 MICA MASS	1
Part I Principles of force, mass, and acceleration	1
Part II Mica mass definitions, mica unit derivations, and sample calculations	14
Notes	24
CHAPTER 2 PLAIN STRING AND WOUND STRING CALCULATIONS	27
Part I Plain strings	27
Part II Wound strings	36
Notes	41
CHAPTER 3 FLEXIBLE STRINGS	44
Part I Transverse traveling and standing waves, and simple harmonic motion in strings	44
Part II Period and frequency equations of waves in strings	54
Part III Length, frequency, and interval ratios of the harmonic series on canon strings	59
Part IV Length, frequency, and interval ratios of non-harmonic tones on canon strings	69
Part V Musical, mathematical, and linguistic origins of length ratios	79
Notes	94
CHAPTER 4 INHARMONIC STRINGS	98
Part I Detailed equations for stiffness in plain strings	98
Part II Equations for coefficients of inharmonicity in cents	108
Part III General equations for stiffness in wound strings	113
Notes	115
CHAPTER 5 PIANO STRINGS VS. CANON STRINGS	118
Part I Transmission and reflection of mechanical and acoustic energy	118
Part II Mechanical impedance and soundboard-to-string impedance ratios	120
Part III Radiation impedance and air-to-soundboard impedance ratios	126
Part IV Dispersion, the speed of bending waves, and critical frequencies in soundboards	130
Part V Methods for tuning piano intervals to beat rates of coincident string harmonics	135
Part VI Musical advantages of thin strings and thin soundboards	141
Notes	143

CHAPTER 6 BARS, RODS, AND TUBES	147
Part I Frequency equations, mode shapes, and restoring forces of free-free bars	147
Part II Free-free bar tuning techniques	160
Part III Frequency equations, mode shapes, and restoring forces of clamped-free bars	174
Part IV Clamped-free bar tuning techniques	176
Notes	178
 CHAPTER 7 ACOUSTIC RESONATORS	 182
Part I Simple harmonic motion of longitudinal traveling waves in air	182
Part II Equations for the speed of longitudinal waves in solids, liquids, and gases	186
Part III Reflections of longitudinal traveling waves at the closed and open ends of tubes	189
Part IV Acoustic impedance and tube-to-room impedance ratio	196
Part V Longitudinal pressure and displacement standing waves in tubes	200
Part VI Length and frequency equations of tube resonators	203
Part VII Theory of cavity resonators	212
Part VIII Cavity resonator tuning techniques	219
Notes	223
 CHAPTER 8 SIMPLE FLUTES	 227
Part I Equations for the placement of tone holes on concert flutes and simple flutes	227
Part II Equations for analyzing the tunings of existing flutes	242
Part III Suggestions for making inexpensive yet highly accurate simple flutes	246
Notes	248
 CHAPTER 9 THE GEOMETRIC PROGRESSION, LOGARITHMS, AND CENTS	 253
Part I Human perception of the harmonic series as a geometric progression	253
Part II Logarithmic processes in mathematics and human hearing	257
Part III Derivations and applications of cent calculations	265
Part IV Logarithmic equations for guitar frets and musical slide rules	271
Notes	276
 CHAPTER 10 WESTERN TUNING THEORY AND PRACTICE	 280
Part I Definitions of prime, composite, rational, and irrational numbers	281
Part II Greek classifications of ratios, tetrachords, scales, and modes	284
Part III Arithmetic and geometric divisions on canon strings	291
Part IV Philolaus, Euclid, Aristoxenus, and Ptolemy	299
Part V Meantone temperaments, well-temperaments, and equal temperaments	334
Part VI Just intonation	365
Notes	460
 CHAPTER 11 WORLD TUNINGS	 485
Part I Chinese Music	485
Notes	504

Part II	Indonesian Music: Java	508
	Bali	522
	Notes	535
Part III	Indian Music: Ancient Beginnings	540
	South India	564
	North India	587
	Notes	600
Part IV	Arabian, Persian, and Turkish Music	610
	Notes	774
CHAPTER 12 ORIGINAL INSTRUMENTS		788
<i>Stringed Instruments:</i>		
	Chrysalis	788
	Harmonic/Melodic Canon	790
	Bass Canon	800
	Just Keys	808
<i>Percussion Instruments:</i>		
	Diamond Marimba	824
	Bass Marimba	826
<i>Friction Instrument:</i>		
	Glassdance	828
<i>Wind Instruments:</i>		
	Simple Flutes	833
CHAPTER 13 BUILDING A LITTLE CANON		834
	Parts, materials, labor, and detailed dimensions	834
	Epilog by Heidi Forster	839
Plate 1:	Chrysalis	845
Plate 2:	Harmonic/Melodic Canon	846
Plate 3:	Bass Canon	847
Plate 4:	String Winder (machine)	848
Plate 5:	String Winder (detail)	849
Plate 6:	Just Keys	850
Plate 7:	Diamond Marimba	851
Plate 8:	Bass Marimba	852
Plate 9:	Glassdance	853
Plate 10:	Glassdance (back)	854
Plate 11:	Simple Flutes	855
Plate 12:	Little Canon	856

Plate 13: Cris Forster with Chrysalis	857
Plate 14: Heidi Forster playing Glassdance	858
Plate 15: David Canright, Heidi Forster, and Cris Forster	859
Plate 16: Chrysalis Foundation Workshop	860
Bibliography for Chapters 1–9	861
Bibliography for Chapter 10	866
Bibliography for Chapter 11	871
Bibliography for Chapter 12	877
Appendix A: Frequencies of Eight Octaves of 12-Tone Equal Temperament	879
Appendix B: Conversion Factors	880
Appendix C: Properties of String Making Materials	882
Appendix D: Spring Steel Music Wire Tensile Strength and Break Strength Values	884
Appendix E: Properties of Bar Making Materials	885
Appendix F: Properties of Solids	888
Appendix G: Properties of Liquids	890
Appendix H: Properties of Gases	892
Index	895

Foreword

I met Cris Forster more than thirty years ago. Shortly thereafter, I saw him perform *Song of Myself*, his setting of Walt Whitman poems from *Leaves of Grass*. His delivery was moving and effective. Several of the poems were accompanied by his playing on unique instruments — one an elegant box with many steel strings and moveable bridges, a bit like a koto in concept; the other had a big wheel with strings like spokes from offset hubs, and he rotated the wheel as he played and intoned the poetry. I was fascinated.

Since that time, Cris has built several more instruments of his own design. Each shows exquisite care in conception and impeccable craftsmanship in execution. And of course, they are a delight to hear. Part of what makes them sound so good is his deep understanding of how acoustic musical instruments work, and part is due to his skill in working the materials to his exacting standards.

But another important aspect of their sound, and indeed one of the main reasons Cris could not settle for standard instruments, is that his music uses scales and harmonies that are not found in the standard Western system of intonation (with each octave divided into twelve equal semitones, called equal temperament). Rather, his music employs older notions of consonance, which reach back as far as ancient Greek music and to other cultures across the globe, based on what is called just intonation. Here, the musical intervals that make up the scales and chords are those that occur naturally in the harmonic series of overtones, in stretched flexible strings, and in organ pipes, for example.

In just intonation, the octave is necessarily divided into unequal parts. In comparison to equal temperament, the harmonies of just intonation have been described as smoother, sweeter, and/or more powerful. Many theorists consider just intonation to be the standard of comparison for consonant intervals. There has been a resurgence of interest in just intonation since the latter part of the twentieth century, spurred by such pioneers as Harry Partch and Lou Harrison. Even so, the community of just intonation composers remains comparatively quite small, and the subset of those who employ only acoustic instruments is much smaller still. I know of no other living composer who has created such a large and varied ensemble of high-quality just intoned acoustical instruments, and a body of music for them, as Cris Forster.

Doing what he has done is not easy, far from it. The long process of developing his instruments has required endless experimentation and careful measurement, as well as intense study of the literature on acoustics of musical instruments. In this way Cris has developed deep and rich knowledge of how to design and build instruments that really work. Also, in the service of his composing, Cris has studied the history of intonation practices, not only in the Western tradition, but around the world.

This book is his generous offering of all that hard-earned knowledge, presented as clearly as he can make it, for all of you who have an interest in acoustic musical instrument design and/or musical scales over time and space. The unifying theme is how mathematics applies to music, in both the acoustics of resonant instruments and the analysis of musical scales. The emphasis throughout is to show how to use these mathematical tools, without requiring any background in higher mathematics; all that is required is the ability to do arithmetic on a pocket calculator, and to follow Cris' clear step-by-step instructions and examples. Any more advanced mathematical tools required, such as logarithms, are carefully explained with many illustrative examples.

The first part of the book contains practical information on how to design and build musical instruments, starting from first principles of vibrating sound sources of various kinds. The ideas are explained clearly and thoroughly. Many beautiful figures have been carefully conceived to illuminate the concepts. And when Cris gives, say, formulas for designing flutes, it's not just something he read in a book somewhere (though he has carefully studied many books); rather, you can be

sure it is something he has tried out: he knows it works from direct experience. While some of this information can be found (albeit in a less accessible form) in other books on musical acoustics, other information appears nowhere else. For example, Cris developed a method for tuning the overtones of marimba bars that results in a powerful, unique tone not found in commercial instruments. Step-by-step instructions are given for applying this technique (see Chapter 6). Another innovation is Cris' introduction of a new unit of mass, the "mica," that greatly simplifies calculations using lengths measured in inches. And throughout Cris gives careful explanations, in terms of physical principles, that make sense based on one's physical intuition and experience.

The latter part of the book surveys the development of musical notions of consonance and scale construction. Chapter 10 traces Western ideas about intonation, from Pythagoras finding number in harmony, through "meantone" and then "well-temperament" in the time of J.S. Bach, up to modern equal temperament. The changing notions of which intervals were considered consonant when, and by whom, make a fascinating story. Chapter 11 looks at the largely independent (though sometimes parallel) development of musical scales and tunings in various Eastern cultures, including China, India, and Indonesia, as well as Persian, Arabian, and Turkish musical traditions. As far as possible, Cris relies on original sources, to which he brings his own analysis and explication. To find all of these varied scales compared and contrasted in a single work is unique in my experience.

The book concludes with two short chapters on specific original instruments. One introduces the innovative instruments Cris has designed and built for his music. Included are many details of construction and materials, and also scores of his work that demonstrate his notation for the instruments. The last chapter encourages the reader (with explicit plans) to build a simple stringed instrument (a "canon") with completely adjustable tuning, to directly explore the tunings discussed in the book. In this way, the reader can follow in the tradition of Ptolemy, of learning about music through direct experimentation, as has Cris Forster.

David R. Canright, Ph.D.
Del Rey Oaks, California
January 2010

Introduction and Acknowledgments

In simplest terms, human beings identify musical instruments by two aural characteristics: a particular kind of sound or timbre, and a particular kind of scale or tuning. To most listeners, these two aspects of musical sound do not vary. However, unlike the constants of nature — such as gravitational acceleration on earth, or the speed of sound in air — which we cannot change, the constants of music — such as string, percussion, and wind instruments — are subject to change. A creative investigation into musical sound inevitably leads to the subject of musical mathematics, and to a reexamination of the meaning of variables.

The first chapter entitled “Mica Mass” addresses an exceptionally thorny subject: the derivation of a unit of mass based on an inch constant for acceleration. This unit is intended for builders who measure wood, metal, and synthetic materials in inches. For example, with the mica unit, builders of string instruments can calculate tension in pounds-force, or lbf, without first converting the diameter of a string from inches to feet. Similarly, builders of tuned bar percussion instruments who know the modulus of elasticity of a given material in pounds-force per square inch, or lbf/in², need only the mass density in mica/in³ to calculate the speed of sound in the material in inches per second; a simple substitution of this value into another equation gives the mode frequencies of uncut bars.

Chapters 2–4 explore many physical, mathematical, and musical aspects of strings. In Chapter 3, I distinguish between four different types of ratios: ancient length ratios, modern length ratios, frequency ratios, and interval ratios. Knowledge of these ratios is essential to Chapters 10 and 11. Many writers are unaware of the crucial distinction between ancient length ratios and frequency ratios. Consequently, when they attempt to define arithmetic and harmonic divisions of musical intervals based on frequency ratios, the results are diametrically opposed to those based on ancient length ratios. Such confusion leads to anachronisms, and renders the works of theorists like Ptolemy, Al-Fārābī, Ibn Sīnā, and Zarlino incomprehensible.

Chapter 5 investigates the mechanical interactions between piano strings and soundboards, and explains why the large physical dimensions of modern pianos are not conducive to explorations of alternate tuning systems.

Chapters 6 and 7 discuss the theory and practice of tuning marimba bars and resonators. The latter chapter is essential to Chapter 8, which examines a sequence of equations for the placement of tone holes on concert flutes and simple flutes.

Chapter 9 covers logarithms, and the modern cent unit. This chapter serves as an introduction to calculating scales and tunings discussed in Chapters 10 and 11.

In summary, this book is divided into three parts. (1) In Chapters 1–9, I primarily examine various vibrating systems found in musical instruments; I also focus on how builders can customize their work by understanding the functions of variables in mathematical equations. (2) In Chapter 10, I discuss scale theories and tuning practices in ancient Greece, and during the Renaissance and Enlightenment in Europe. Some modern interpretations of these theories are explained as well. In Chapter 11, I describe scale theories and tuning practices in Chinese, Indonesian, and Indian music, and in Arabian, Persian, and Turkish music. For Chapters 10 and 11, I consistently studied original texts in modern translations. I also translated passages in treatises by Ptolemy, Al-Kindī, the Ikhwān al-Ṣafā, Ibn Sīnā, Stifel, and Zarlino from German into English; and in collaboration with two contributors, I participated in translating portions of works by Al-Fārābī, Ibn Sīnā, Ṣafī Al-Dīn, and Al-Jurjānī from French into English. These translations reveal that all the above-mentioned theorists employ the language of ancient length ratios. (3) Finally, Chapters 12 and 13 recount musical instruments I have built and rebuilt since 1975.

I would like to acknowledge the assistance and encouragement I received from Dr. David R. Canright, associate professor of mathematics at the Naval Postgraduate School in Monterey,

California. David's unique understanding of mathematics, physics, and music provided the foundation for many conversations throughout the ten years I spent writing this book. His mastery of differential equations enabled me to better understand dispersion in strings, and simple harmonic motion of air particles in resonators. In Section 4.5, David's equation for the effective length of stiff strings is central to the study of inharmonicity; and in Section 6.6, David's figure, which shows the effects of two restoring forces on the geometry of bar elements, sheds new light on the physics of vibrating bars. Furthermore, David's plots of compression and rarefaction pulses inspired numerous figures in Chapter 7. Finally, we also had extensive discussions on Newton's laws. I am very grateful to David for his patience and contributions.

Heartfelt thanks go to my wife, Heidi Forster. Heidi studied, corrected, and edited myriad versions of the manuscript. Also, in partnership with the highly competent assistance of professional translator Cheryl M. Buskirk, Heidi did most of the work translating extensive passages from *La Musique Arabe* into English. To achieve this accomplishment, she mastered the often intricate verbal language of ratios. Heidi also assisted me in transcribing the Indonesian and Persian musical scores in Chapter 11, and transposed the traditional piano score of "The Letter" in Chapter 12. Furthermore, she rendered invaluable services during all phases of book production by acting as my liaison with the editorial staff at Chronicle Books. Finally, when the writing became formidable, she became my sparring partner and helped me through the difficult process of restoring my focus. I am very thankful to Heidi for all her love, friendship, and support.

I would also like to express my appreciation to Dr. John H. Chalmers. Since 1976, John has generously shared his vast knowledge of scale theory with me. His mathematical methods and techniques have enabled me to better understand many historical texts, especially those of the ancient Greeks. And John's scholarly book *Divisions of the Tetrachord* has furthered my appreciation for world tunings.

I am very grateful to Lawrence Saunders, M.A. in ethnomusicology, for reading Chapters 3, 9, 10, and 11, and for suggesting several technical improvements.

Finally, I would like to thank Will Gullette for his twelve masterful color plates of the Original Instruments and String Winder, plus three additional plates. Will's skill and tenacity have illuminated this book in ways that words cannot convey.

Cris Forster
San Francisco, California
January 2010

TONE NOTATION

	32'	16'	8'	4'	2'	1'	1/2'	1/4'	1/8'
--	-----	-----	----	----	----	----	------	------	------

1.	C ₀	C ₁	C ₂	C ₃	C ₄	C ₅	C ₆	C ₇	C ₈
2.	C _∞	C _∞	C	c	c'	c''	c'''	c''''	c ^v
3.	C ₂	C ₁	C ₀	c ⁰	c ¹	c ²	c ³	c ⁴	c ⁵

1. American System, used throughout this text.
2. Helmholtz System.
3. German System.

LIST OF SYMBOLS

Latin

12-TET	12-tone equal temperament
a	Acceleration; in/s^2
a.l.r.	Ancient length ratio; dimensionless
B	Bending stiffness of bar; $\text{lbf}\cdot\text{in}^2$, or $\text{mica}\cdot\text{in}^3/\text{s}^2$
B'	Bending stiffness of plate; $\text{lbf}\cdot\text{in}$, or $\text{mica}\cdot\text{in}^2/\text{s}^2$
B_A	Adiabatic bulk modulus; psi , lbf/in^2 , or $\text{mica}/(\text{in}\cdot\text{s}^2)$
B_I	Isothermal bulk modulus; psi , lbf/in^2 , or $\text{mica}/(\text{in}\cdot\text{s}^2)$
b	Width; in
ϵ	Cent, 1/100 of a “semitone,” or 1/1200 of an “octave”; dimensionless
$\bar{\epsilon}$	Coefficient of inharmonicity of string; cent
c_B	Bending wave speed; in/s
c_L	Longitudinal wave speed, or speed of sound; in/s
c_T	Transverse wave speed; in/s
c.d.	Common difference of an arithmetic progression; dimensionless
c.r.	Common ratio of a geometric progression; dimensionless
cps	Cycle per second; $1/\text{s}$
D	Outside diameter; in
D_i	Inside diameter of wound string; in
D_m	Middle diameter of wound string; in
D_o	Outside diameter of wound string; in
D_w	Wrap wire diameter of wound string; in
d	Inside diameter, or distance; in
E	Young’s modulus of elasticity; psi , lbf/in^2 , or $\text{mica}/(\text{in}\cdot\text{s}^2)$
F	Frequency; cps
F_c	Critical frequency; cps
F_n	Resonant frequency; cps
\bar{F}_n	Inharmonic mode frequency of string; cps
f	Force; lbf , or $\text{mica}\cdot\text{in}/\text{s}^2$
f.r.	Frequency ratio; dimensionless
g	Gravitational acceleration; $386.0886 \text{ in}/\text{s}^2$
h	Height, or thickness; in
I	Area moment of inertia; in^4
i.r.	Interval ratio; dimensionless
J	Stiffness parameter of string; dimensionless
K	Radius of gyration; in
k	Spring constant; lbf/in , or mica/s^2
L	Length; in , cm , or mm
ℓ_M	Multiple loop length of string; in
ℓ_S	Single loop length of string; in
l.r.	Length ratio; dimensionless
lbf	Pounds-force; $\text{mica}\cdot\text{in}/\text{s}^2$
lbm	Pounds-mass; 0.00259008 mica

$M/u.a.$	Mass per unit area; mica/in ² , or lbf·s ² /in ³
$M/u.l.$	Mass per unit length; mica/in, or lbf·s ² /in ²
m	Mass; mica, or lbf·s ² /in
n	Mode number, or harmonic number; any positive integer
P	Pressure; psi, lbf/in ² , or mica/(in·s ²)
p	Excess acoustic pressure; psi, lbf/in ² , or mica/(in·s ²)
psi	Pounds-force per square inch; lbf/in ² , or mica/(in·s ²)
q	Bar parameter; dimensionless
R	Ideal gas constant; in·lbf/(mica·°R), or in ² /(s ² ·°R)
r	Radius; in
S	Surface area; in ²
SHM	Simple harmonic motion
T	Tension; lbf, or mica·in/s ²
T_A	Absolute temperature; dimensionless
t	Time; s
U	Volume velocity; in ³ /s
u	Particle velocity; in/s
V	Volume; in ³
v	Phase velocity; in/s
W	Weight density, or weight per unit volume; lbf/in ³ , or mica/(in ² ·s ²)
w	Weight; lbf, or mica·in/s ²
Y_A	Acoustic admittance; in ⁴ ·s/mica
Z_A	Acoustic impedance; mica/(in ⁴ ·s)
Z_r	Acoustic impedance of room; mica/(in ⁴ ·s)
Z_t	Acoustic impedance of tube; mica/(in ⁴ ·s)
Z_M	Mechanical impedance; mica/s
Z_b	Mechanical impedance of soundboard; mica/s
Z_p	Mechanical impedance of plate; mica/s
Z_s	Mechanical impedance of string; mica/s
Z_R	Radiation impedance; mica/s
Z_a	Radiation impedance of air; mica/s
z	Specific acoustic impedance; mica/(in ² ·s)
z_a	Characteristic impedance of air; 0.00153 mica/(in ² ·s)

Greek

Δ	Correction coefficient, or end correction coefficient; dimensionless
$\Delta\ell$	Correction, or end correction; in, cm, or mm
δ	Departure of tempered ratio from just ratio; cent
γ	Ratio of specific heat; dimensionless
θ	Angle; degree
κ	Conductivity; in
Λ	Bridged canon string length; in
Λ_A	Arithmetic mean string length; in
Λ_G	Geometric mean string length; in
Λ_H	Harmonic mean string length; in

λ	Wavelength; in
λ_B	Bending wavelength; in
λ_L	Longitudinal wavelength; in
λ_T	Transverse wavelength; in
μ	Poisson's ratio; dimensionless
Π	Fretted guitar string length; mm
π	Pi; ≈ 3.1416
ρ	Mass density, or mass per unit volume; mica/in ³ , or lbf·s ² /in ⁴
τ	Period, or second per cycle; s

1 / MICA MASS

There is nothing obvious about the subject of mass. For thousands of years mass remained undefined until Isaac Newton (1642–1727) published his *Principia Mathematica* in 1687. The mass density of a material as signified by the lowercase of the Greek letter *rho* (ρ) appears in all acoustic frequency equations and in many other equations as well. Unfortunately, the concept of mass persists in a shroud of unnecessary complexity and confusion. This is especially true for those who measure distances in inches. Unlike the metric system, which has two consistent mass-distance standards (the kilogram-meter combination and the gram-centimeter combination), the English system has only one consistent mass-distance standard: the slug-foot combination. Not only is the latter standard totally inadequate for musical instrument builders, but countless scientists and engineers who use inches have acknowledged the need for a second English mass unit. (See Note 19.) Although no one has named such a unit, many designers and engineers do their calculations as though it exists. This practice is completely unacceptable. Reason tells us that a measurement in inches should be just as admissible as a measurement in meters, centimeters, or feet. And yet, when someone substitutes inch measurements into an equation that also requires a mass density value, they cannot calculate the equation without a specialized understanding for an undefined and unnamed mass unit. To dispense with this practice, the following chapter defines and names a new unit of mass called *mica*. Throughout this book we will use a consistent mica-inch standard (see Equation 1.15) designed to make frequency and other related calculations easily manageable.

Readers not interested in the subject of mass may simply disregard this chapter. If all your distance measurements are in inches, turn to Appendix C or E, find the mass density of a material in the mica/in³ column, substitute this value for ρ into the equation, and calculate the result. This chapter is for those interested in gaining a fundamental understanding of mass. In Part I, we will discuss principles of force, mass, and acceleration, and in Part II, mica mass definitions, mica unit derivations, and sample calculations. Although some of this material may seem inappropriate to discussions on the acoustics of musical instruments, readers with a thorough understanding of mass will avoid many conceptual and computational errors.

Part I

PRINCIPLES OF FORCE, MASS, AND ACCELERATION

≈ 1.1 ≈

All musical systems such as strings, bars, membranes, plates, and columns of air vibrate because they have (1) an elastic property called a restoring force, and (2) an inertial property called a mass. When we pluck a string, or strike a marimba bar, we apply an initial force to the object that accelerates it from stillness to motion. Our applied force causes a displacement, or a small distortion

of the object's original shape. Because the string has tension, and because the bar has stiffness, a restoring force responds to this displacement and returns the object to its equilibrium position. (Gently displace and release a telephone cord, and note how this force restores the cord to the equilibrium position. Now try the same experiment with a piece of paper or a ruler.) However, because the string and the bar each have a mass, the motion of the object continues beyond this position. Mass causes the object to overshoot the equilibrium position, which in turn causes another distortion and a subsequent reactivation of the restoring force, etc. To understand in greater detail how force and mass interact to produce musical vibrations,¹ we turn to Newton's first law of motion.

According to Newton's first law, (1) an object at rest remains at rest, and in the absence of friction, (2) an object in motion remains in motion, unless acted on by a force. This law states that all objects have inertia; that is, all objects have a resistance to a change in either the *magnitude* or the *direction* of motion. (1) An object without motion will not move unless a force acts to cause motion. (2) An object in motion will not speed up, slow down, stop, or change direction unless a force acts to cause such changes. Newton quantified this inertial property of matter and called it the *mass* (m) of an object. Therefore, an object's mass is a measure of its inertia.

Refer now to Figure 1.1 and consider the motion of a slowly vibrating rubber cord. If we pluck such a cord (or any musical instrument string), it will snap back to its equilibrium position, but it will not simply stop there. (a) As we displace the cord upward, tension (the *elastic property* of the cord) acts as a restoring force (f) that pulls the cord in a downward direction. (b) After we release the cord and as it moves toward the equilibrium position, its particle velocity² (u) increases while the restoring force decreases.³ During this time, tension is acting in a downward direction and the cord is moving downward. (c) Upon reaching the equilibrium position, the cord has maximum velocity for the instant that the restoring force = 0, and therefore the cord's acceleration = 0. According to Newton's first law, the cord continues to move past this position because the cord's mass (the *inertial property* of the cord) will not stop moving, or change direction, unless a force acts to cause such changes.⁴ (d) Once through the equilibrium position, the restoring force reverses direction. Consequently, the velocity decreases because the restoring force is working in the opposite direction of the cord's motion. During this time, tension acts in an upward direction as the cord moves downward. (e) At a critical moment when the restoring force is at a maximum, the cord comes to rest and, for an instant, the velocity is zero. (f) Immediately after this moment, the cord reverses its direction and returns to the equilibrium position. Once again, the cord's velocity increases while the restoring force decreases. During this time, tension is acting in an upward direction and the cord is moving upward. (g) After the cord passes through the equilibrium position, (h) the restoring force again reverses direction, and the cord's velocity decreases. (i) When the restoring force is at a maximum, the cord comes to rest. This position marks the beginning of the next cycle.

≈ 1.2 ≈

Before we proceed, let us first distinguish between the *vertical* particle velocity of a string, and the *horizontal* transverse speed of waves in a string.⁵ As transverse waves travel horizontally in the string, each particle of the string moves vertically up and down; that is, each particle moves at right angles to the direction of wave propagation. Furthermore, the vertical motion of musical instrument strings is also due to the principle of superposition. Superposition occurs when two transverse waves traveling horizontally in opposite directions combine and produce a third wave that vibrates in a vertical direction. Such waves are called standing waves.⁶ (See Sections 3.1 and 3.3.) The purpose of Figure 1.1 is to illustrate the function of tension and mass in the motion of transverse standing waves. Since the existence of transverse standing waves in strings depends on the presence of transverse traveling waves, it follows that particle velocity calculations depend on transverse wave

2 / PLAIN STRING AND WOUND STRING CALCULATIONS

In Western music, strings constitute the primary source of musical sound. This is a remarkable fact because instrument builders encounter serious structural problems when they attempt to tune strings over a wide range of frequencies. The laws of vibrating strings clearly demonstrate the difficulties involved in building stringed instruments with a range of six or more “octaves.” Despite these obstacles, piano and harp builders persevered and eventually solved the range problem by overwinding plain strings with copper, bronze, and silver wire. Wound strings replace the need for extremely long plain strings. Furthermore, because of their rich tone, wound strings are also found on narrow range instruments like violins and guitars. To help distinguish between these two different kinds of strings and their respective calculations, this chapter is divided into two parts. Part I covers plain strings, and Part II, wound strings. In both parts, discussions center on mass per unit length, string length, and tension calculations. Finally, we will also consider constructive and destructive aspects of the force of tension.

Part I

PLAIN STRINGS

≈ 2.1 ≈

The most commonly cited frequency equation for plain and wound strings is

$$F_n = \frac{n}{2L} \sqrt{\frac{T}{M/u.l.}}$$

where F_n is the frequency of a given harmonic or mode of vibration, in cycles per second; n is the mode number, any positive integer; L is the overall length of a flexible string, in inches; T is the tension, in pounds-force (lbf); and $M/u.l.$ is the mass per unit length, in mica per inch. (For a definition of the mica mass unit, see Section 1.10.) Since this chapter focuses primarily on the fundamental frequencies of strings, we now rewrite this equation to read

$$F_1 = \frac{1}{2L} \sqrt{\frac{T}{M/u.l.}} \tag{2.1}$$

where F_1 is the frequency of the first harmonic or the first mode of vibration, in cps.

The $M/u.l.$ variable in Equation 2.1 does not consist of a simple measurable quantity. Rather, it expresses the ratio of a mass to a unit length. For plain strings, mass per unit length calculations

are straightforward, but for wound strings, they are complicated. In either case, the mass per unit length ratio deserves special consideration because it appears in several equations. Looking ahead, we find the $M/u.l.$ variable in equations for calculating the transverse wave speed¹ (c_T), the dimensionless stiffness parameter² (J), and the characteristic mechanical impedance³ (Z_s) of plain strings.

≈ 2.2 ≈

Two equations enable us to calculate the $M/u.l.$ variable of plain strings. The first equation states

$$M/u.l. = \frac{m}{L} \quad (2.2)$$

where m is the total mass of the string, in micas.⁴ Equation 2.2 requires a highly accurate scale. Suppose such a scale indicates that a plain string with a length of 19.25 inches has a weight of 0.006178 lbf, and therefore a mass of 0.006178 lbm.⁵ Turn to Appendix B, find the lbm-to-mica conversion factor, and make the following conversion:

$$(0.006178 \text{ lbm}) \left(\frac{1.0 \text{ mica}}{386.09 \text{ lbm}} \right) = 0.000016002 \text{ mica}$$

Now substitute the values for m and L into Equation 2.2 and calculate the string's mass per unit length:

$$M/u.l. = \frac{0.000016002 \text{ mica}}{19.25 \text{ in}} = 0.0000008313 \text{ mica/in}$$

Although this technique is mathematically valid, it is not very practical. Given thousands of material-and-length combinations, the empirical method of weighing and measuring individual string samples is extremely time consuming and expensive. When faced with many stringing possibilities, musical instrument builders have good reason to do all their mass per unit length calculations on paper.

≈ 2.3 ≈

The second $M/u.l.$ equation⁶ for plain strings states

$$M/u.l. = \pi r^2 \rho \quad (2.3)$$

where r is the radius of the string, in inches; and ρ is the mass density, or the mass per unit volume of the stringing material, in mica per cubic inch.⁷ Notice that Equation 2.3 takes into account the radius, or the diameter of the string. However, if we examine this equation more closely, it seems inappropriate that πr^2 , the equation for the area of a two-dimensional plane figure (a circle), should appear in an equation designed to calculate the mass per unit length of a three-dimensional solid (a cylinder). Before we explain the reason for this apparent contradiction in the context of Equation 2.3, let us reconsider Equation 2.2.

A plain string has the geometric shape of a cylinder. Placing a string on a scale gives the cylinder's total mass. As an alternative, the following equation allows us to simply calculate the mass of a cylinder:

$$m_{\text{cylinder}} = V\rho \quad (2.4)$$

3 / FLEXIBLE STRINGS

Perfectly flexible strings do not exist. All strings must exhibit a minimum amount of stiffness; otherwise, they could not resist the force of tension. However, from a mathematical perspective the study of ideal strings is important because some strings have a tendency to behave as though they were perfectly flexible. This is especially true for strings that are long, thin, and very flexible. Such strings tend to produce higher mode frequencies that are near perfect integer multiples of a fundamental frequency. The physical presence of such “harmonics,” and the mathematical language used to describe them, have greatly influenced our thoughts, ideas, and opinions about music. Since the 6th century B.C., when Pythagoras discovered the relationship between vibrating string lengths and musical intervals, countless experiments have been conducted and hundreds of treatises have been written to explain the nature of vibrating strings and the art of tuning to ratios. Although much of this knowledge has great value, it is in the spirit of firsthand experience that we begin our analysis in Part I by focusing on traveling waves, standing waves, and simple harmonic motion in strings. We then continue in Part II with period and frequency equations of waves in strings; in Part III, with length, frequency, and interval ratios of the harmonic series and on canon strings; in Part IV, with length, frequency, and interval ratios of non-harmonic tones, also on canon strings; and in Part V, with the musical, mathematical, and linguistic origins of length ratios.

Part I

TRANSVERSE TRAVELING AND STANDING WAVES, AND SIMPLE HARMONIC MOTION IN STRINGS

≈ 3.1 ≈

When we snap a rubber cord with a single rapid up-and-down motion of the hand, a *pulse* in the shape of a crest will begin to travel along the cord. Two such rapid motions of the hand in quick succession produce a *sine wave* in the shape of a crest and a trough. By definition, a wave (or one complete oscillation) consists of a positive (upward) displacement and a negative (downward) displacement of the cord. In contrast, a pulse (or one-half oscillation) is a simpler kind of wave because it consists only of a single positive or negative displacement. For this reason, we will begin the discussion on waves in strings by examining pulses in cords because they are easier to observe and illustrate.

Figure 3.1(a) shows the motion of a pulse as a crest. As it advances, individual particles of the cord move in an upward transverse direction at the leading edge of the pulse, and in a downward transverse direction at the trailing edge. For a pulse as a trough, Figure 3.1(b) shows that the cord particles move downward at the leading edge and upward at the trailing edge. Note carefully that in both examples the cord moves vertically up and down as the pulse travels horizontally from left to

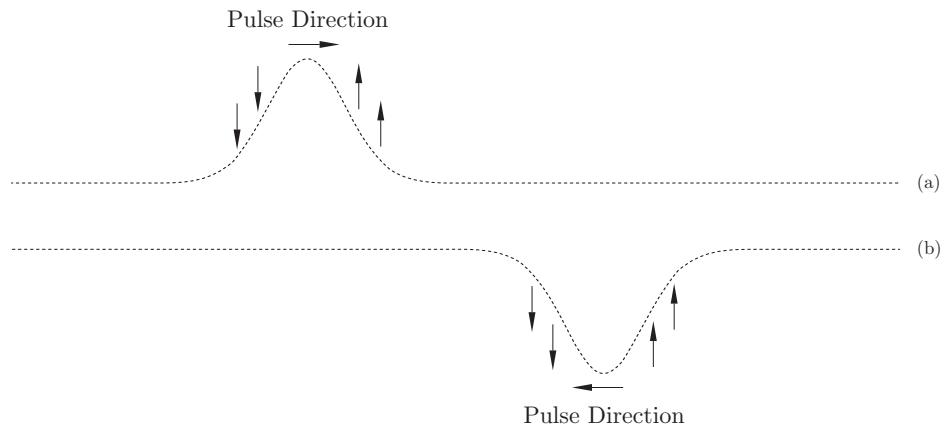

Figure 3.1 Vertical particle motion of a cord. (a) As a traveling pulse in the shape of a crest moves from left to right, vertical arrows indicate an initial upward motion followed by a downward motion of particles in the cord. (b) As a traveling pulse in the shape of a trough moves from right to left, vertical arrows indicate an initial downward motion followed by an upward motion of particles in the cord.

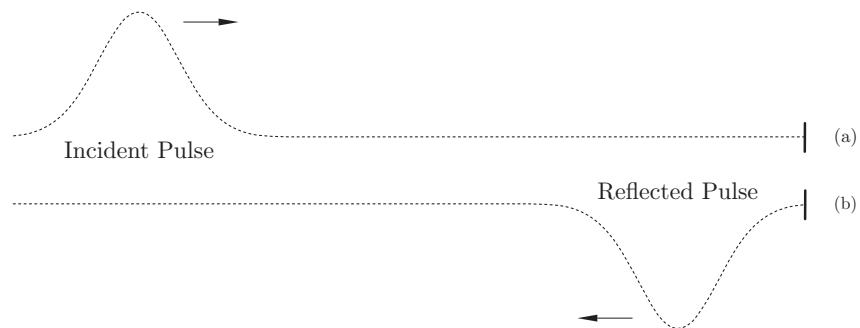

Figure 3.2 Reflection of a pulse. (a) An incident pulse in the shape of a crest travels from left to right. (b) After reflecting from a rigid support, the same pulse in the shape of a trough travels from right to left.

4 / INHARMONIC STRINGS

In Chapter 3, we used Equation 3.13 to calculate the frequencies of string harmonics as exact integer multiples of the fundamental frequency. Further discussions focused on the mathematical structure of the harmonic series and the subsequent organization of musical ratios. Although integer ratios (see Section 3.13) are important to scales and tuning, a detailed examination of vibrating strings reveals that exact integer harmonics do not exist. When we multiply a given fundamental frequency by a sequence of integers, the result is a series of resonant frequencies that is only theoretically correct. On any given string, a true harmonic series could only occur if the string were perfectly flexible. Since all strings exhibit varying degrees of *stiffness*, the flexible string model no longer applies. Stiffness causes the modes to vibrate at frequencies considerably higher than suggested by Equation 3.13. For this reason, we call the sharp mode frequencies of stiff strings *inharmonic mode frequencies* (\bar{F}_n), a term that refers to *non-integer* multiples of the fundamental frequency.

This chapter consists of three parts. In Part I, we will consider equations for stiffness in plain strings; in Part II, equations for calculating coefficients of inharmonicity in cents; and in Part III, equations for stiffness in wound strings.

Part I

DETAILED EQUATIONS FOR STIFFNESS IN PLAIN STRINGS

≈ 4.1 ≈

The language used to describe vibrating strings and other kinds of vibrating systems is of special interest to this discussion. Figure 3.10 shows the first six *modes of vibration* of a flexible string, and Figure 4.1 shows the first four modes of a stiff string. The term *mode* refers to the simplest physical patterns, shapes, or forms a vibrating system is capable of producing. The frequency associated with a given mode shape is called the resonant frequency, the natural frequency, or the mode frequency of the system. Within this context, the noun or adjective *mode* does *not* define a particular kind of pattern or frequency, so that a mode frequency may be either harmonic or inharmonic.

Regarding perfectly flexible strings, however, we consistently call the mode frequencies *harmonics*. This term (as in “second harmonic”) has a strict definition: it includes only those frequencies that are integer multiples of the fundamental frequency. Mode frequencies of stiff strings are, therefore, not included. When describing stiff strings, we should not refer to the frequency of the “second harmonic” if we mean the “second inharmonic.” Since the latter term sounds contrived, we will use the word *mode* (as in “frequency of the second mode,” or “second mode frequency”) to correctly identify a noninteger or inharmonic frequency.

≈ 4.2 ≈

To understand why the inharmonic mode frequencies of stiff strings sound higher than the harmonic mode frequencies of flexible strings, recall that for ideal strings,

$$F_n = \frac{c_T}{\lambda_n} \quad (4.1)$$

where F_n is the mode frequency, in cps; c_T is the transverse wave speed, in inches per second; and λ_n is the mode wavelength, in inches. Note that the numerator of this equation requires only one transverse wave speed, which indicates that in flexible strings c_T is constant. This is decidedly *not* the case for stiff strings. The influence of stiffness significantly alters both the mode wave speeds and the mode wavelengths of vibrating strings. Therefore, to calculate the inharmonic mode frequencies of stiff strings we must now rewrite Equation 4.1 to state

$$\bar{F}_n = \frac{c_{n \text{ eff}}}{\lambda_{n \text{ eff}}} \quad (4.2)$$

where $c_{n \text{ eff}}$ is the effective mode wave speed; and $\lambda_{n \text{ eff}}$ is the effective mode wavelength.

In comparison to flexible strings, the mode wave speeds in stiff strings are not constant. Instead, stiffness causes the effective wave speeds to *increase* with each higher mode of vibration. Consequently, no two modes have the same wave speed. Furthermore, in stiff strings the effective vibrating length (L_{eff}) is *shorter* than the measured length of the string. Since for flexible strings, $\lambda_n = 2L/n$, we find that for stiff strings,

$$\lambda_{n \text{ eff}} = \frac{2L_{\text{eff}}}{n} \quad (4.3)$$

Solutions to Equation 4.2 require detailed analyses of the physical properties of strings. A simpler method consists of a purely mathematical approach. This equation states

$$\bar{F}_n = nF\sqrt{1 + 2J(n^2 - 1)} \quad (4.4)$$

where \bar{F}_n is the inharmonic mode frequency *relative* to the fundamental frequency (F); J is the dimensionless stiffness parameter of the string (see Sections 4.3–4.4); and n is the mode number, any positive integer. Equations 4.2 and 4.4 give virtually identical results. In this chapter, we will examine the former equation because it focuses on the mechanical aspects of vibrating strings, and the latter because it offers convenient solutions.

≈ 4.3 ≈

Mathematicians use a dimensionless stiffness parameter to calculate the influence of stiffness on the mode wave speeds, the mode wavelengths, and the mode frequencies of vibrating strings. It is, therefore, highly appropriate to start the mechanical analysis of stiff strings with two different equations for J . The first equation, by Robert W. Young, includes a tension variable;¹ and the second, by Harvey Fletcher, includes a frequency variable.² Young's equation states

$$J = \frac{\pi^2 ESK^2}{2TL^2} \quad (4.5)$$

where E is Young's modulus of elasticity, in pounds-force per square inch, or psi; S is the cross-sectional area of the string, in square inches; K is the radius of gyration, in inches; T is the tension of the string, in pounds-force; and L is the measured length of the string, in inches. Before proceeding, simplify this equation. The variables S and K^2 represent two subequations that include the radius (r) of the string:

$$S = \pi r^2$$

$$K^2 = \left(\frac{r}{2}\right)^2$$

5 / PIANO STRINGS VS. CANON STRINGS

The problems associated with inharmonic piano strings are far more severe than stretched “octaves” tuned 30 ¢ sharp in the treble and 30 ¢ flat in the bass. (See Sections 4.16–4.17.) Stiff strings constitute a primary source of harmonic and melodic dissonance. For this reason, no piano builder has ever intentionally increased the inharmonicity of an instrument by installing thick strings. On the contrary, all builders design their instruments with the thinnest strings possible. Even so, conventional piano strings do not encourage musical exploration and, therefore, do not advance the development of acoustic music. Most piano tuning experiments end in failure. Unless the builder understands the nature of inharmonically induced dissonance, and attempts to restring a piano with thin strings, the authentic rendition of a scale — based on the intervals of the harmonic series — remains in doubt. All scales and tunings benefit from flexible strings. Such strings are ideal because they produce truer harmonics and, thereby, minimize the obliterating effects of excessive inharmonicity.

If inharmonicity is not just an obscure technical subject, then the *musical* question arises: “Why are the dimensionless stiffness parameters (J), or the coefficients of inharmonicity ($\bar{\epsilon}$), of typical piano strings so high?” (See Table 4.1.) In a word, the answer is “Power!” Since the early 18th century when Bartolomeo Cristofori (1655–1730) built his first *gravicembalo col piano e forte*, or *harpsichord with soft and loud*, the primary goal of all builders consisted of a single-minded determination to make the grand piano as loud as humanly possible. At the beginning of the 20th century, this process came to an inevitable end. To understand why instrument builders could not make the piano any “grandier,” we must discuss three fundamental concepts of the physics of stringed instruments: (1) the transfer of energy from strings to soundboard and into the surrounding air; (2) the mechanical wave impedances of strings and soundboards, and the radiation impedance of air; and (3) the phenomenon of dispersion in soundboards. We will explore these subjects in Parts I–IV, and in Part V, examine how piano tuners tune intervals to the beat rates of coincident string harmonics. Finally, in Part VI a mathematical analysis will demonstrate the musical advantages of thin strings and thin soundboards. In short, while thick strings and thick soundboards produce very loud sounds, these heavy mechanical components severely restrict the intonational possibilities of all modern pianos.

Part I

TRANSMISSION AND REFLECTION OF MECHANICAL AND ACOUSTIC ENERGY

≈ 5.1 ≈

Sound production in a piano may be traced by way of an energy chain that begins when a finger delivers a force of sufficient magnitude to depress a key. The *mechanical energy* resulting from this

force is then transferred through the key to the action levers, to the hammer, to the string(s), and finally to the soundboard. Here mechanical energy is transformed and radiated as *acoustic energy* (sound waves) into the surrounding air. From finger to soundboard, every link in this chain is associated with a force, and the amount of energy in the system (how loud or soft the piano sounds at any given time) is directly proportional to the magnitude of these forces.

However, to produce loud sounds, generating large forces is not enough. The amplification of sound is also dependent on an efficient displacement of large amounts of air. A vibrating string or tuning fork radiates only small amounts of sound because the surface area of either object displaces very little air. When the same string or tuning fork contacts a soundboard or table top, and *transfers* its vibrational energy to a larger surface, the radiation of sound increases dramatically. Suddenly, upon contacting a large structure, a faint sound becomes clearly audible from a distance. For pianos, both the initial intensity (how loud or soft the strings will sound) and the ensuing duration (how long or short the strings will continue to vibrate) depend not only on the forces of the energy chain, but also on the critical rate at which vibrational energy is transferred from the strings to the soundboard. Consequently, if the string-to-soundboard proportion is incorrect, no amount of pounding (forcing) will contribute to the desired dynamic range.

≈ 5.2 ≈

Consider for a moment two extremely different situations that illustrate how a wave either *transmits* most of its energy (with intensity and no duration), or *reflects* most of its energy (with duration and no intensity) at the boundary between the string and the soundboard. In the first example, a string is coupled over a bridge to a very thin wood plate designed to move as though it were a physical extension of the string. A wave traveling on the string would barely notice the boundary, and would transmit most of its energy (without significant reflection) at the bridge. As a result, the plate would respond to this rapid transfer of vibrational energy with a loud (but brief) pitchless

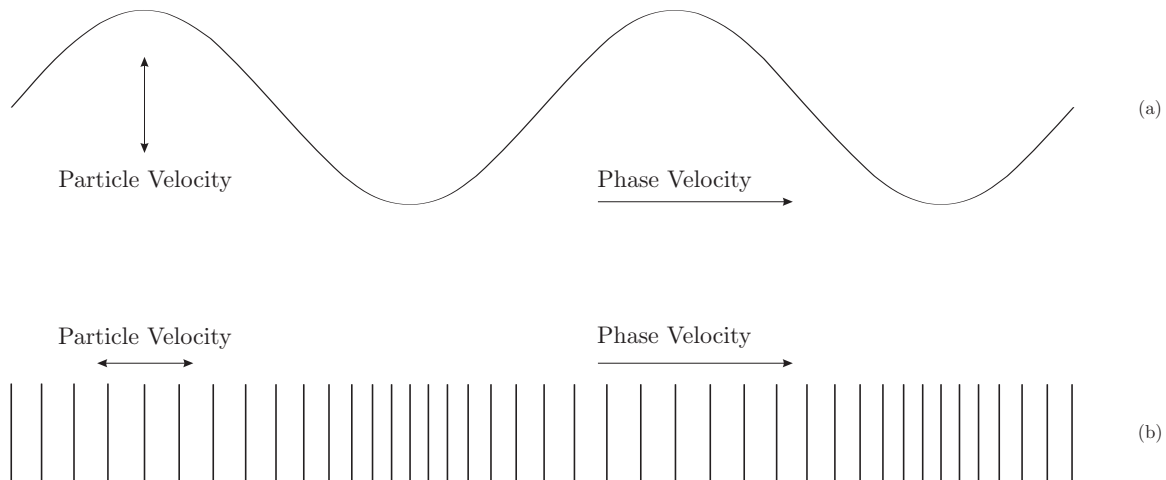

Figure 5.1 Particle and phase velocities in solids and fluids. (a) In solids, the particle velocity (u) is *perpendicular* to the phase velocity (v). In this chapter, the phase velocity refers to the speed of transverse waves in strings (c_T), or the speed of transverse bending waves in soundboards (c_B). (b) In fluids, the particle velocity is *parallel* to the phase velocity. Here the phase velocity refers to the speed of longitudinal sound waves in air (c_L). See Sections 5.14–5.15 for detailed descriptions on the speed (c) of waves. In either case, the particle velocity is associated with the *amplitude*, while the phase velocity is associated with the *frequency* of a wave.

6 / BARS, RODS, AND TUBES

On first impression, it seems that marimbas, orchestral chimes, mbiras,¹ and harmonicas do not have many common properties. From a mathematical perspective, however, musical instruments made from bars, rods, or tubes fall into two principal groups. The first group consists of bars, rods, or tubes that are free at both ends. All the instruments in the free-free group are percussion instruments such as marimbas, xylophones, vibraphones, celestas, gamelan bars, orchestra bell bars, glockenspiels, bell lyras, orchestral chimes, metal tubes,² solid rods,³ and tuning forks.⁴ The second group consists largely of bars and reeds clamped at one end. The instruments in this group are either percussion instruments or wind instruments because some are played with mallets or fingers, whereas others are driven with compressed air. Percussion instruments in the clamped-free group include mbiras, slit drums, music boxes, and jaw's harps; wind instruments include reed organ pipes, accordions, harmonicas, harmoniums, and concertinas.

A mathematical classification is important because it emphasizes the acoustical similarities among different kinds of musical instruments. For example, all the instruments in the free-free group produce identical mode shapes; this also applies to the clamped-free group. Consequently, the principles and techniques used to tune rosewood marimba bars and aluminum tubes are the same; similarly, the tuning techniques of steel mbira keys and brass harmonica reeds are also the same. Because there are more similarities than differences in the frequency equations and mode shapes of the objects belonging to either group, the phrase “bars, rods, and tubes” will appear only when appropriate. Future discussions will primarily focus on free-free bars and clamped-free bars with the understanding that rods and tubes are included as well.

Because of the overall complexity of this subject, and some significant differences between free-free bars and clamped-free bars, this chapter is divided into four parts. Part I examines frequency equations, mode shapes, and restoring forces of free-free bars, and Part II gives a detailed description of free-free bar tuning techniques. Part III examines the frequency equations, mode shapes, and restoring forces of clamped-free bars, and Part IV gives a brief description of clamped-free bar tuning techniques.

Part I

FREQUENCY EQUATIONS, MODE SHAPES, AND RESTORING FORCES OF FREE-FREE BARS

≈ 6.1 ≈

Stiff strings, soundboards, and bars have one common property: a restoring force due to stiffness. When an object vibrates under the influence of stiffness, two important characteristics come to mind. (1) In strings, stiffness causes increases in the speed of transverse waves (c_T), and in soundboards

and bars, stiffness causes increases in the speed of transverse bending waves (c_B). (2) As a result of such increases in mode wave speeds, these vibrating systems produce mode frequencies that do not form a harmonic series. We call such frequencies *inharmonic mode frequencies* because they are *not* integer multiples of a fundamental frequency.

The general topic of increasing mode wave speeds falls under the subject known as *dispersion*. This phenomenon received a great deal of attention in Sections 4.8 and 5.14. The reader should read, study, and absorb this material because it is essential for a thorough understanding of vibrating bars. Bars are extremely dispersive; here stiffness acts as the *only* restoring force that returns a vibrating bar to its equilibrium position. However, there exists an important difference between stiff strings and ribbed soundboards on the one hand, and bars on the other. Only in bars are tuners of percussion instruments able to methodically change the restoring force due to stiffness and, thereby, intentionally tune the inharmonic modes to a wide variety of alternate frequencies.

≈ 6.2 ≈

The frequency equation for a slender, uniform, isotropic bar, rod, or tube free at both ends states⁵

$$F_{n \text{ free-free}} = \frac{\pi K \sqrt{E/\rho}}{8} \left(\frac{q_n}{L} \right)^2 \left. \begin{array}{l} q_1 \approx 3.01124 \approx 3.0112 \\ q_2 \approx 4.99951 \approx 5 \\ q_3 \approx 7.00002 \approx 7 \\ q_4 \approx 8.99999 \approx 9 \\ q_{n>4} \approx 2n + 1 \end{array} \right\} \quad (6.1)$$

where F_n is the mode frequency of transverse vibrations, in cps; E is Young's modulus of elasticity of the material, in pounds-force per square inch, or psi; ρ is the mass density, or mass per unit volume of the material, in mica per cubic inch;⁶ L is the length of the object, in inches; q_n is a dimensionless bar parameter; and K is the radius of gyration of the object, in inches. In Section 6.7, turn to Table 6.1, find K for bars, and rewrite Equation 6.1 to read

$$F_{n \text{ bar}} = \frac{\pi (h/\sqrt{12}) \sqrt{E/\rho}}{8} \left(\frac{q_n}{L} \right)^2 \quad (6.2)$$

where h is the height or thickness of the bar, in inches.

The dimensionless bar parameter depends on the end conditions of the bar and on the mode of vibration.⁷ Although rational approximations $q_2 \approx 5$, $q_3 \approx 7$, . . . seem justified, the exact values of q_n represent irrational numbers.⁸ Therefore, none of the higher mode frequencies of free-free bars are true harmonics. (See Equation 3.13.) Instead, all the modes consist of inharmonic frequencies not found in the harmonic series. The following frequency ratios define the relations between the fundamental frequency and the frequencies of the second, third, and fourth modes:

$$F_2 \propto \left(\frac{q_2}{q_1} \right)^2 \approx 2.757$$

$$F_3 \propto \left(\frac{q_3}{q_1} \right)^2 \approx 5.404$$

$$F_4 \propto \left(\frac{q_4}{q_1} \right)^2 \approx 8.933$$

7 / ACOUSTIC RESONATORS

Vibrating bars do not radiate sound very efficiently. To amplify the radiation of sound from bars, instrument builders mount tuned acoustic resonators underneath the bars of marimbas, xylophones, and vibraphones.¹ Acoustic resonators fall into two categories. The most common type consists of a straight cylindrical tube made of bamboo, metal, or plastic that is open at the top end and closed on the bottom end. Length and frequency equations for tube resonators are easy to understand, and building a set of such resonators is not very difficult. The other kind of acoustic resonator consists of a regularly or irregularly shaped cavity.² On African marimbas and xylophones one frequently finds hollow spherical or tubular gourd resonators, and on central American marimbas, flared pyramidal resonators made of wood.³ Although the mathematics of cavity resonators are far more complicated than the mathematics of tube resonators, building and tuning such resonators does not require a detailed knowledge of complex equations. Instead, to construct such resonators, all one needs is a basic knowledge of cavity resonator mechanics, coupled with patience, experience, and a little bit of luck.

Since the acoustic principles of these two types of resonators are very different, this chapter consists of two different areas: Parts I–VI cover tube resonators, and Parts VII–VIII cover cavity resonators. Furthermore, because vibrating air columns in narrow tubes constitute the principal sound-producing systems of flutes, Parts I–VI also serve as an essential introduction to Chapter 8. Included in this discussion will be the propagation of longitudinal traveling waves or sound waves in the surrounding air and in tubes, the reflection of longitudinal traveling waves at the open and closed ends of tubes, the acoustic impedances of tubes and rooms, and the formation of pressure and displacement standing waves in tubes. Readers who need immediate access to tube resonator equations should refer to Section 7.11, which cites length and frequency equations for tubes open at both ends (called *open* tubes), and tubes open at one end and closed on the other end (called *closed* tubes). Also, Section 7.12 includes three important practical considerations for anyone interested in building tube resonators.

Part I

SIMPLE HARMONIC MOTION OF LONGITUDINAL TRAVELING WAVES IN AIR

≈ 7.1 ≈

The single most important motion associated with the vibrations of all acoustic musical instruments is called *simple harmonic motion*. SHM describes the periodic motion of a particle in a solid, liquid, or gas as it vibrates in a linear direction about its equilibrium position. To observe SHM in a string, return for a moment to the slow motions of a flexible cord in Figure 3.5. The positions of

the arrows indicate that in one second, every crest and trough advances the distance of one wavelength (λ) to the right. Furthermore, the position of a given dot in each frame illustrates that every displaced particle in the cord undergoes simple harmonic motion. That is, each particle moves in a linear positive direction above its equilibrium position, and in a linear negative direction below its equilibrium position. This kind of disturbance is called a *transverse traveling wave* because the direction of particle motion is *perpendicular* to the direction of wave propagation.⁴

Now, if one plucks a stretched string fixed at both ends, the string's fundamental mode of vibration will produce a transverse standing wave pattern⁵ as shown in a sequence of nine string displacements along the left edge of Figure 7.1. Such a disturbance causes a compression of air particles in front of the string's leading surface, and a rarefaction of air particles behind the string's trailing surface. By definition, a compression is an area of positive pressure or high molecular density, and a rarefaction is an area of negative pressure or low molecular density. Again, notice that the positions of the arrows in each frame show that for a frequency of 1.0 cps, every center of compression and rarefaction advances the distance of one wavelength per second to the right. Moreover, the locations of circles around a given air particle indicate that every particle undergoes SHM. A particle near a compression moves in a forward or positive direction to the right, and near a rarefaction, in a backward or negative direction to the left. Therefore, positive pressure causes a propulsion of air particles in the forward direction, and negative pressure causes a suction of air particles in the backward direction. Note again that only the acoustic energy associated with the disturbance travels in the direction of wave propagation.

A close examination of SHM shows that when $t = 0$ s, the marked particle in Figure 7.1 is passing through the equilibrium position. At this location, the particle has maximum velocity. When $t = \frac{1}{8}$ s, the particle is moving in the positive direction, and at $t = \frac{1}{4}$ s, it reaches maximum positive displacement. Here the velocity = 0. When $t = \frac{3}{8}$ s, the particle is now moving in the negative direction. At $t = \frac{1}{2}$ s, the particle again passes through the equilibrium position. Now, observe the following unique feature of a longitudinal traveling wave. When a particle passes through the equilibrium position, and moves in the same direction as the longitudinal wave, it is located at the center of a compression. This occurs when $t = 0$ s, $t = 1.0$ s, $t = 2.0$ s, etc. Conversely, when a particle passes through the equilibrium position, and moves in the opposite direction of the longitudinal wave, it is located at the center of a rarefaction. This occurs when $t = \frac{1}{2}$ s, $t = 1\frac{1}{2}$ s, $t = 2\frac{1}{2}$ s, etc. When $t = \frac{5}{8}$ s, the particle continues its movement in the negative direction, and at $t = \frac{3}{4}$ s, it reaches maximum negative displacement. Here again, the velocity = 0. Finally, when $t = \frac{7}{8}$ s, the particle is now moving again in the positive direction, and at $t = 1.0$ s, it returns to the same position as in the first frame. This position marks the beginning of the next cycle.

We may also view this motion by looking straight down onto the page. Imagine the nine marked particles in the pathway of a pendulum bob as it swings back and forth between the left and right margins of the page. Note, therefore, that only the mechanical energy associated with the disturbance travels in the direction of wave propagation. The particles of the medium do not travel, but simply oscillate about their respective equilibrium positions. This kind of disturbance is called a *longitudinal traveling wave* or *sound wave* because the direction of particle motion is *parallel* to the direction of wave propagation.

Let us now examine a spring-mass system designed to demonstrate simple harmonic motion. Figure 7.2 shows that such a system consists of two distinct parts: a spring or elastic component that restores the system to its equilibrium position, and a mass or inertial component that causes the system to overshoot its equilibrium position.⁶ Aspects of these two mechanical or acoustical components belong to *all* vibrating systems. Scientists refer to the spring-mass system as a *lumped system* because both parts exist independently of each other. In contrast, most vibrating systems and musical instruments are called *distributed*⁷ or *continuous*⁸ systems because a clear physical

8 / SIMPLE FLUTES

Flutes, harps, and drums are the oldest musical instruments created by man. Wind instruments are unique, however, because they alone embody the physical dimensions of scales and tunings. In a work entitled *The Greek Aulos*, Kathleen Schlesinger (1862–1953) attempted to reconstruct Greek music theory by analyzing the remains of ancient reed flutes.¹ It is possible to approach the subject of flute tunings from two different perspectives. We may predict the tuning of an existing instrument by first measuring various flute bore, embouchure hole, and tone hole dimensions, and then substituting these data into a sequence of equations. This method provides convenient solutions when a flute is extremely fragile and cannot be played, or is simply not available for playing. On the other hand, we may realize a given tuning by making a flute according to another sequence of equations. From a mathematical perspective, these two approaches are distinctly different and require separate discussions.

As all experienced flute players know, the intonation of a transverse flute — with either a very simple or a very complex embouchure hole — depends not only on the precision of instrument construction, but also on the performer. The mathematics of flute tubes, embouchure holes, and tone holes does not necessarily produce an accurate sounding instrument. The intonation of a flute is also governed by the strength of the airstream, and by the amount the lips cover the embouchure hole. Because these two variables exist beyond the realm of mathematical predictability, they depend exclusively on the skill of the performer.

Due to the overall complexity of flutes, this chapter is divided into three parts. Part I investigates equations for the placement of tone holes, and Part II, mathematical procedures required to analyze existing flutes. Since Part II is unintelligible without a thorough understanding of Part I, the reader should study this chapter from beginning to end. Finally, Part III gives some suggestions on how to make very inexpensive yet highly accurate simple flutes.

Part I

EQUATIONS FOR THE PLACEMENT OF TONE HOLES ON CONCERT FLUTES AND SIMPLE FLUTES

≈ 8.1 ≈

In writing this chapter, I am indebted to Cornelis J. Nederveen. In his book entitled *Acoustical Aspects of Woodwind Instruments*,² Nederveen carefully defines all the mathematical variables needed for a thorough investigation into woodwind acoustics. Numerous tables of woodwind instrument dimensions are included at the end of the book. Because a full description of flute acoustics requires many different variables, this discussion begins with a list of symbols originally defined by Nederveen. Since most of these symbols appear only in this chapter, they are not included in the List of Symbols at the beginning of this book. Furthermore, the List of Flute Symbols below gives

seven symbols that do not appear in Nederveen's book: effective length $L_{B(h)}$ replaces λ_H ; effective length $L_{B(e)}$ replaces λ_E ; correction $\Delta\ell_E$ replaces $L_{B(e)}$ in the context of flute length calculations; corrections $\Delta\ell_H$ and $\Delta\ell_T$, and length ℓ_T , represent simplifications. Finally, L_A replaces L_S when, in predicting the frequencies of an existing flute, we cannot determine L_S , which represents an *exact* acoustic half-wavelength; in this context, we must calculate L_A , which represents an *approximate* acoustic half-wavelength. In preparation for Chapter 8, the reader should read, study, and absorb Chapter 7. Knowledge of longitudinal pressure waves and end correction terminology is essential for an understanding of flute acoustics.

LIST OF FLUTE SYMBOLS

d_1	Bore diameter at tone hole.
d_0	Bore diameter at embouchure hole.
d_H	Tone hole diameter.
d_E	Embouchure hole diameter.
S_E	Surface area of embouchure hole.
S_0	Surface area of bore at embouchure hole.
ℓ_H	Geometric or measured length (or height) of tone hole; that is, (1) the shortest distance of a tone hole chimney on a concert flute with key pads, or (2) the wall thickness of a simple flute without key pads.
L_H	Acoustic or effective length of tone hole. (See Note 13.)
$L_{B(h)}$	Acoustic or effective length of bore at tone hole. (Nederveen: λ_H , p. 64.)
ℓ_E	Geometric or measured length of embouchure hole.
L_E	Acoustic or effective length of embouchure hole. (See Note 13.)
$L_{B(e)}$	Acoustic or effective length of bore at embouchure hole. (Nederveen: λ_E , p. 26.)
Δ	Correction coefficient.
$\Delta\ell_E$	Approximate correction at embouchure hole. In principle, the same as $L_{B(e)}$. Although $\Delta\ell_E$ does not have an exact mathematical value, $\Delta\ell_E$ is always greater than $L_{B(e)}$.
$\Delta\ell_H$	Correction at tone hole. (Nederveen: L_X , p. 13; and zL_S , p. 48.)
$\Delta\ell_T$	End correction at open tube end: $0.3d_1$. (Nederveen: ξa , p. 27.)
$\Delta\ell_K$	Correction at key pad. (Nederveen: $\Delta\ell_d$, p. 64.)
h	Geometric or measured distance of key pad in the open position above the center of a tone hole.

9 / THE GEOMETRIC PROGRESSION, LOGARITHMS, AND CENTS

Cent calculations provide a highly accurate method to measure the relative sizes of musical intervals. Equation 9.21 shows a convenient method for computing cent values on calculators equipped with LOG keys. However, because texts on music theory and musical instrument construction seldom discuss logarithms and cents in full detail, many aspects of this analytical technique remain obscure. Furthermore, technical difficulties often occur because instrument builders, music theorists, and ethnomusicologists utilize different kinds of numerical notation to record their data. For example, suppose a researcher gives an Indonesian 7-tone *pélog* scale in cents, and a flute maker wants to build an instrument in that tuning. This problem raises the inevitable question, “How does one convert cents into decimal ratios?” Or, a piano tuner who wants to increase the pitch of an instrument might ask, “What changes in frequency and, therefore, in string tension will occur if I raise A_4 -440.0 cps by 25 ¢?” Answers to these and other related questions require thorough investigations into logarithms and cents. Once achieved, such a study provides a powerful tool for understanding many different tuning systems throughout the world.

In preparation for this chapter, the reader should read, study, and absorb the following topics discussed in Chapter 3: (1) the mathematical structure of the harmonic series, (2) the distinctions between ancient length ratios, modern length ratios, frequency ratios, and interval ratios, and (3) the mathematical methods used in the division of canon strings. In Part I of this chapter we will discuss human perception of the harmonic series as a geometric progression; in Part II, logarithmic processes in mathematics and human hearing; in Part III, the derivation and application of cent calculations; and in Part IV, logarithmic equations for the placement of guitar frets, and for the construction of musical slide rules.

Part I

HUMAN PERCEPTION OF THE HARMONIC SERIES AS A GEOMETRIC PROGRESSION

≈ 9.1 ≈

We begin this discussion by considering two fundamental mathematical sequences: the arithmetic progression, and the geometric progression. Because these two progressions have profound and far-reaching consequences, we will encounter them in many different contexts.

One may write an arithmetic progression by beginning with a given number a , and then repeatedly *adding* a constant number d . For example, the following sequence:

2, 5, 8, 11, 14

is an arithmetic progression in which $d = 3$. Since d represents a difference between consecutive terms, it is called the *common difference* (c.d.) of an arithmetic progression. A general expression for an arithmetic progressions states

$$a, a + d, a + 2d, a + 3d, \dots$$

One may write a geometric progression by beginning with a given number a , and then repeatedly *multiplying* by a constant number r . For example, the following sequence:

$$2, 6, 18, 54, 162$$

is a geometric progression in which $r = 3$. Since r represents a ratio between consecutive terms, it is called the *common ratio* (c.r.) of a geometric progression. A general expression for a geometric progression states

$$a, ar, ar^2, ar^3, \dots$$

Notice that the exponents of a geometric progression form an arithmetic progression, where c.d. = 1. Also, observe that the former arithmetic progression has a uniform increase (3, 3, 3, 3) between terms, while the latter geometric progression has a varied increase (4, 12, 36, 108) between terms.

≈ 9.2 ≈

A mathematical and a musical examination of Figure 9.1 shows that we may interpret the harmonic series as an arithmetic progression *or* as a geometric progression. The arithmetic progression consists of a simple sequence of harmonics numbered 1, 2, 3, . . . which continues theoretically to infinity. Each harmonic generates a frequency that is an integer multiple of the fundamental frequency. So, if the first harmonic of a flexible string,¹ or an open column of air,² produces C_2 at 65.0 cps, then the first five harmonics of this arithmetic progression generate frequencies

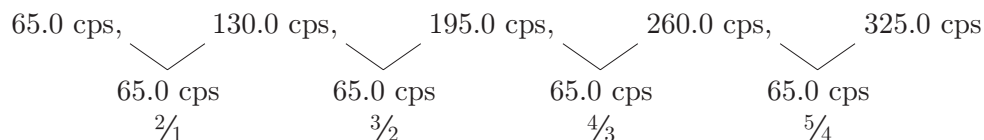

Although the harmonics of this particular arithmetic progression have a common difference, where c.d. = 65.0 cps, the human ear *cannot* identify a recurring interval pattern between the consecutive tones of the harmonic series. Figure 9.1 shows that with increases in frequencies, the intervals between harmonics never repeat, and simply become progressively smaller. Consequently, the harmonic series as an arithmetic progression is musically meaningless!

In contrast, when a sequence of frequencies forms a geometric progression, the human ear *can* identify a recurring interval pattern between tones. The underlined harmonics below constitute such a progression:

$$\underline{1}, \underline{2}, 3, \underline{4}, 5, 6, 7, \underline{8}, 9, 10, 11, 12, 13, 14, 15, \underline{16}, 17, \dots \tag{i}$$

Upon hearing these five harmonics, musicians recognize four identical musical intervals. Again, if the first harmonic C_2 vibrates at 65.0 cps, then the underlined harmonics of the latter geometric progression generate frequencies

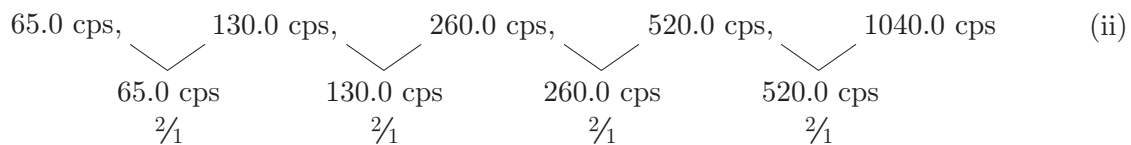

10 / WESTERN TUNING THEORY AND PRACTICE

Approximately 2500 years ago, the semi-legendary Greek philosopher and mathematician Pythagoras (*c.* 570 B.C. – *c.* 500 B.C.) reputedly discovered the crucial nexus between sound and number. Since that time, numbers in the form of ratios enabled musicians to accurately control the tuning of their instruments, and provided mathematicians with a means to analyze and classify new scales and tunings. The numeration of music presented common ground to musicians and mathematicians, and inspired a rich tradition of cooperation and controversy that lasted well into the 18th century. Unfortunately, for the last two hundred years, a tendency toward specialization in the arts and sciences produced a deep chasm between music and mathematics. Due to the universal standardization of 12-tone equal temperament, and a coexisting lack of development in the construction of new musical instruments, recent generations of musicians have shown very little interest in mathematics. As a result, the history of music in the West since the time of the ancient Greeks consists largely of an innocuous recounting of “music theory.” However, since one cannot intelligently discuss music theory without confronting the subject of consonance and dissonance, and since the latter topic has its roots in polemics over scales and tunings, the exclusion of mathematics from music constitutes a deplorable aberration at best. Only a mathematical approach to music brings to full consciousness the possibilities of consonances and dissonances not yet heard. This in essence is the legacy of the Greek mathematician and astronomer Claudius Ptolemy (*c.* A.D. 100 – *c.* 165). In the *Harmonics*, Ptolemy continuously demonstrates to his reader that the ancient synthesis of music and mathematics inculcates an inner capacity for diversity, and encourages verification through experimentation.

The subject of tuning theory and practice is truly vast and could easily fill a half-dozen volumes. To help organize and limit the discussion, this chapter is divided into six parts. Part I analyzes formal mathematical definitions of four different types of numbers; Part II, Greek classifications of musical ratios, tetrachords, scales, and modes; Part III, arithmetic and geometric divisions on canon strings; and Part IV, scales by Philolaus, Euclid, Aristoxenus, and Ptolemy. In Table 10.12, Ptolemy’s Catalog of Scales also includes tunings by Archytas, Eratosthenes, and Didymus. The remaining parts focus on two areas in the recent history of Western tuning: Part V covers tempered tunings, and Part VI, just intoned tunings.

Chapters 3 and 9 are indispensable to an understanding of this chapter. As discussed in Chapter 3, the reader should know: (1) the mathematical structure of the harmonic series, (2) the distinctions between ancient length ratios, modern length ratios, frequency ratios, and interval ratios, and (3) the mathematical methods used in the division of canon strings. Furthermore, as discussed in Chapter 9, the reader should also know: (1) the distinction between an arithmetic progression and a geometric progression, (2) the procedure by which the human ear “adds” and “subtracts” musical intervals, and why this is equivalent to the multiplication and division of ratios, and (3) how to

convert length ratios and frequency ratios into cents. Furthermore, as discussed in Sections 9.2–9.3, 9.8, and 9.13, the reader should also fully understand the intellectual and mathematical processes that make all equal temperaments, and in particular 12-tone equal temperament, possible. In summary, the intellectual process states that in the context of the harmonic series, the human ear identifies interval patterns according to geometric progressions, and it recognizes a single musical interval by its signature interval ratio. The mathematical process states that geometric progressions, frequency ratios, and interval ratios are governed by operations of multiplication and division. Therefore, with respect to 12-tone equal temperament, a *geometric division* of ratio $\frac{2}{1}$ into 1200 equal parts requires the extraction of the twelve-hundredth root of 2.

A simple canon with six or more strings and moveable bridges (see Chapter 13) is an essential tool for a musical understanding of this chapter, but not a requirement for intellectual comprehension. Perhaps some day the discussions in this chapter will inspire a reader to build such an instrument.

Part I

DEFINITIONS OF PRIME, COMPOSITE, RATIONAL, AND IRRATIONAL NUMBERS

≈ 10.1 ≈

The numbers that constitute musical ratios are called real numbers. Real numbers consist of both rational and irrational numbers. A rational number is defined as the quotient of two integers. With respect to scales and tunings, the integers that constitute musical ratios are classified as positive natural numbers, which include all odd numbers, even numbers, and prime numbers. Therefore, by definition, ratios such as $\frac{x}{y}$, where variables x and y represent positive integers, are called *integer ratios*.

Definition 1. A prime number is an integer whose only divisors are itself and 1. For example, 3 is a prime number because only 3 and 1 divide this number without a remainder. The first ten prime numbers are

$$2, 3, 5, 7, 11, 13, 17, 19, 23, 29, \dots$$

Note that 1 is not a prime number,¹ and that 2 is the only even prime number.

Definition 2. An integer greater than 1 that is not a prime number is called a composite number. The first ten composite numbers are

$$4, 6, 8, 9, 10, 12, 14, 15, 16, 18, \dots$$

All composite numbers may be factored into prime numbers. To determine the prime factors of a composite number, divide the number by primes until the result is a prime. For example, the following factorization:

$$\frac{42}{7} = 6, \quad \frac{6}{3} = 2$$

reveals that composite number 42 is a product of prime numbers $7 \times 3 \times 2$.

A factorization into primes enables one to understand the numerical and musical structure of a ratio. Consider the factorization

$$\frac{4}{2} = 2$$

11 / WORLD TUNINGS

When Westerners speak of music as a universal language, they more than likely think of a symphony orchestra performance in China or Japan, or some other musical product exported from the occident to the orient. Long before I began writing this book, I envisioned discussing Chinese, Indonesian, Indian, and Arabian tuning theory in the same breath as Greek and Renaissance tuning theory. Why not? Music is a universal language not only because human beings have ears and a desire to make music, but also because people all over the world cultivate and investigate the subject of musical mathematics.

Most listeners to whom “foreign” music sounds “funny” never get past a first impression because they lack the artistic and scientific tools to analyze their initial response. If prejudice is the expression of personal opinion without a consideration of facts, then understanding is the expression of personal opinion based on a willingness to consider facts. In this context, a factual examination of another civilization may lead to the following questions: When a Chinese musician tunes the strings of a *ch'in*, and when a European musician tunes the strings of a harpsichord, how are these two tunings alike, and how are they different? However, such comparisons alone do not meet the requirements for true understanding. One must also ask, “Does an examination of facts further the experience of listening to music from distant civilizations?” If your answer is “yes,” then read on.

The reading requirements for Chapter 11 are the same as outlined at the beginning of Chapter 10. The reader should also study Sections 10.1–10.2, and know the definitions of prime numbers, composite numbers, rational numbers, and irrational numbers. However, a complete reading of Chapter 10 is not required. Throughout Chapter 11, I have intentionally avoided references to Western tuning and music theory wherever possible. Finally, this chapter consists of four parts. Part I examines Chinese music; Part II, Indonesian music; Part III, Indian music; and Part IV, Arabian, Persian, and Turkish music. Due to the vastness of these subjects, I have selected only a few basic concepts from each civilization. Without these considerations, no fundamental understanding is possible.

Part I

CHINESE MUSIC

≈ 11.1 ≈

Of the texts that have survived, the earliest detailed description of Chinese tuning practice exists in a book entitled *Lü-shih ch'un-ch'iu* (*The Spring and Autumn of Lü Pu-wei*), written *c.* 240 B.C.¹ According to this narrative, the semi-legendary emperor Huang Ti (fl. *c.* 2700 B.C.) ordered music master Ling Lun to cast a set of sixty bells, and to tune them in twelve sets of five bells each. To accomplish this task, Ling Lun used the original 12-tone scale, where each scale degree provided

him with a fundamental tone from which to tune the original pentatonic scale. The oldest extant source that gives detailed calculations for this 12-tone scale is a book by Ssu-ma Ch'ien (c. 145 B.C. – c. 87 B.C.) entitled *Shih Chi (Records of the Historian)*, written c. 90 B.C.² Here, Ssu-ma Ch'ien cites the famous formula

*San fen sun i fa: Subtract and add one-third.*³

for the calculation of 12 pitch pipe lengths. An ancient pitch pipe consists of a tube closed at one end. One plays a pitch pipe like a panpipe by blowing across the open end of the tube. Ssu-ma Ch'ien's formula works equally well for string lengths. Equations 7.18 and 3.10 indicate that these two vibrating systems are very similar. The former equation states that the theoretical wavelength of the fundamental tone of a closed tube equals four times the length of the tube; and the latter equation, that the theoretical wavelength of the fundamental tone of a string equals two times the length of the string. However, because the frequencies of tubes are affected by end corrections,⁴ lip coverage at the embouchure hole,⁵ and the strength of a player's airstream,⁶ the following discussion will focus on strings; the frequencies of the latter are easier to predict and control. Furthermore, since Ssu-ma Ch'ien based his calculations on a closed tube 8.1 units long,⁷ and since fractional lengths are inconvenient, we will use an overall string length of 9 units. This length occurs in many historical texts, including a work entitled *Lung-yin-kuan ch'in-p'u* by Wang Pin-lu (1867–1921). Pin-lu's student, Hsü Li-sun, edited and renamed this manuscript *Mei-an ch'in-p'u*, and published it in 1931. Fredric Lieberman translated the latter in his book *A Chinese Zither Tutor*.⁸ We will refer to this work throughout Sections 11.5–11.7.

≈ 11.2 ≈

The ancient formula *subtract and add one-third* consists of two mathematical operations that have opposite effects. Subtraction of a string's $\frac{1}{3}$ length yields variable L_{short} , and addition of a string's $\frac{1}{3}$ length yields variable L_{long} . However, in the context of scale calculations, one may obtain identical results through the following operations of division and multiplication. (1) The act of subtracting $\frac{1}{3}$ from a string's vibrating length (L) is equivalent to dividing L by ancient length ratio $\frac{3}{2}$, or multiplying L by modern length ratio $\frac{2}{3}$:

$$L_{\text{short}} = L - \frac{L}{3} = \frac{L}{\frac{3}{2}} = L \times \frac{2}{3}$$

(2) The act of adding $\frac{1}{3}$ to a string's decreased length is equivalent to multiplying L_{short} by ancient length ratio $\frac{4}{3}$:

$$L_{\text{long}} = L_{\text{short}} + \frac{L_{\text{short}}}{3} = L_{\text{short}} \times \frac{4}{3}$$

(3) Similar to the first operation, the act of subtracting $\frac{1}{3}$ from a string's increased length is equivalent to dividing L_{long} by ancient length ratio $\frac{3}{2}$, or multiplying L_{long} by modern length ratio $\frac{2}{3}$:

$$L_{\text{short}} = L_{\text{long}} - \frac{L_{\text{long}}}{3} = \frac{L_{\text{long}}}{\frac{3}{2}} = L_{\text{long}} \times \frac{2}{3}$$

For a string 9.0 units long, Table 11.1 shows that the Chinese up-and-down principle of scale generation produces string lengths accurate to five decimal places.

Part II
INDONESIAN MUSIC

Java

≈ 11.12 ≈

Indonesia consists of an archipelago of three thousand islands scattered throughout the Indian Ocean in Southeast Asia. It is the birthplace of gamelan music. Gamelan orchestras, composed of many low-lying and stationary musical instruments arranged in rectangular or circular patterns, bring to mind unique islands of sound. Gamelan music defies standard mathematical analysis because among the thousands of orchestras that exist in Indonesia, no two are alike. For unknown reasons, the tradition of monochord division did not flourish in Indonesia, and consequently tuning theory did not evolve as a branch of mathematics. Instead, the subject of musical mathematics developed on a purely *experiential* basis. Each village and town has its own individual sound, and for a given gamelan, professional gamelan makers tune their instruments, without the benefit of acoustic or electronic devices, to within a few cents of a desired scale. Given the inharmonic mode frequencies of vibrating bars¹ and gongs, such precision in the tuning of percussion instruments constitutes a remarkable scientific and musical achievement.

Gamelans on the islands of Java and Bali are tuned to two basic scales, or *laras*, called *sléndro* and *pélog*. Musicians East and West write gamelan music in cipher notation, which consists of a progression of integers that represent the tones of a piece composed in either *sléndro* or *pélog*. Unfortunately, unless one understands the idiosyncrasies of this notation, it is extremely easy to misinterpret the pitches of gamelan tunings. Before we discuss this subject in full detail, let us first review the cipher notation in Section 11.5 and Figure 11.2. Many scholars record the original Chinese pentatonic scale by writing 1–2–3–5–6–1, where the last digit represents a tone an “octave” above the first digit. Figure 11.3 shows that this technique has its origins in the Chev e System,² which uses numbers 1 through 7 to identify the sequential tones of the standard Western diatonic scale. For a tone an “octave” above a given pitch, the cipher-dot notation requires a dot above a cipher, and for a tone an “octave” below a given pitch, a dot below a cipher; similarly, it requires two dots above or below a cipher for a tone two “octaves” above or below a given pitch. When one compares the pitches of the original Chinese pentatonic scale to five select pitches of the Western diatonic scale, the sequence 1–2–3–5–6–1 represents the Chinese scale fairly well.

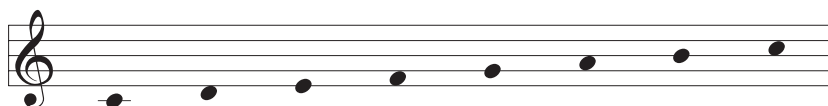

Chev�e System, or diatonic cipher notation:	1	2	3	4	5	6	7	1̇
Chinese pentatonic cipher notation:	1	2	3		5	6		1
Original Chinese pentatonic scale:	1/1	9/8	81/64		3/2	27/16		2/1
Original Chinese pentatonic scale in cents:	0	203.9	407.8		702.0	905.9		1200.0

Figure 11.3 The Chev e System, or diatonic cipher notation used in many ethnomusicological texts. Here the sequence 1–2–3–4–5–6–7–1̇ represents one “octave” of the standard Western diatonic scale. When applied to the original Chinese pentatonic scale in Figure 11.2, the sequence reads 1–2–3–5–6–1, which represents the latter scale fairly well.

Sléndro consists of a 5-tone or pentatonic scale. An application of the latter sequence of ciphers to this scale does not yield favorable results. Regrettably, since most writers do not bother to discuss these inherent difficulties, the transmission of accurate information suffers. Avoidance of such discussions is based on two perplexing facts: (1) No two gamelans have identical tunings, and (2) differences in tuning may vary significantly. This lack of consistency is the hallmark of gamelan tunings and, when viewed from a musical perspective, is the source of endless artistic inspiration. However, given an accurate set of numbers, there is no reason why science should suffer at the expense of art. Reliable tuning data reveal tendencies *not* supported by conventional cipher notation. For example, Figure 11.4, Row 2, indicates that the *sléndro* tuning system is traditionally notated 1–2–3–5–6–1̣, which immediately suggests the original Chinese pentatonic scale, or a spiral of “fifths.” In contrast, Figure 11.4, Row 3, shows recalculated average cent values of 28 Javanese *sléndro* gamelans analyzed by Wasisto Surjodiningrat, *et al.*³ Note that in the majority of cases, traditional pitch 3 *tends* to sound like a “flat fourth,”⁴ as in frequency ratio $\frac{21}{16}$ [470.8 ¢], and not like a “sharp major third,” ratio $\frac{81}{64}$ [407.8 ¢]. Similarly, traditional pitch 6 *tends* to sound like a “flat minor seventh,”⁵ as in ratio $\frac{7}{4}$ [968.8 ¢], and not like a “sharp major sixth,” ratio $\frac{27}{16}$ [905.9 ¢]. Because traditional pitches 3 and 6 are generally tuned a “semitone” higher than enumerated, we should write *sléndro* as 1–2–4–5–7♭–1̣, and if not, we should understand it as such.⁶ Furthermore, *sléndro* and *pélog* “octaves” are frequently tuned about a *syntonic comma*, ratio $\frac{81}{80}$ [21.5 ¢], sharp.⁷ This technique gives many gamelans a shimmering musical quality because “sharp octaves” cause very noticeable beat rate patterns on powerful percussion instruments made of bronze. So, to acknowledge this unique and vital feature of many Javanese gamelans, it would not be entirely incorrect to notate *sléndro* 1–2–4–5–7♭–1̣♯, as in Figure 11.4, Row 1, to indicate such “sharp octaves.”

A complete or double gamelan consists of a set of instruments tuned in *sléndro*, and a set of instruments tuned in *pélog*. Consider now the *sléndro* scale of a *saron demung*, a percussion instrument with seven bronze bars, which belongs to a famous double gamelan called Kyahi Kanjutmesem.⁸ (Since Surjodiningrat, *et al.* give all frequencies rounded to zero decimal places, I will do the same with respect to the *related* frequency and cent calculations below. However, wherever warranted, I will also continue to give frequency and cent values carried out to one decimal place.) This instrument is tuned to the following frequencies: 248 cps, 287 cps, 331 cps, 378 cps, 435 cps, 500 cps, and 580 cps. Here *sléndro* begins on the second bar, and the “sharp octave” resides on the seventh bar. Since D₄ of 12-TET vibrates at 293.7 cps, and since the second bar vibrates at 287 cps, or 40.0 ¢ flat of D₄, observe that the first note in Figure 11.4 does *not* reflect this pitch. Instead, the cent values in Figure 11.4, Row 4, were calculated relative to the frequency of the *second* bar, or to the first pitch of the *sléndro* scale. According to Equation 9.21,

$$\text{Pitch 2} = \log_{10} \frac{331 \text{ cps}}{287 \text{ cps}} \times 3986.314 = 247 \text{ ¢}$$

$$\text{Pitch 3} = \log_{10} \frac{378 \text{ cps}}{287 \text{ cps}} \times 3986.314 = 477 \text{ ¢} \dots$$

The tones in Figures 11.4 and 11.5 only give very rough approximations of the cent averages in Rows 3. Refer to the 5-limit analysis in Figure 11.4, Row 5, and notice that *sléndro* in its simplest form consists of two ascending $\frac{3}{2}$'s, or two ascending “fifths”: [Pitch 5 = $\frac{1}{1} \times \frac{3}{2} = \frac{3}{2}$], [Pitch 2 = $\frac{3}{2} \times \frac{3}{2} = \frac{9}{4} = \frac{9}{8}$], and two descending $\frac{3}{2}$'s, or two descending “fifths”: [Pitch 3 = $\frac{1}{1} \div \frac{3}{2} = \frac{2}{3} = \frac{4}{3}$], [Pitch 6 = $\frac{4}{3} \div \frac{3}{2} = \frac{8}{9} = \frac{16}{9}$]. However, because pitch 6 tends to sound like a “flat minor seventh,” note carefully that a typical *sléndro* scale does *not* have an interval of a “major third.” To help identify extremely sharp or flat sounding pitches, Figures 11.4 and 11.5 show such tones with arrows pointing upward or downward, respectively; these arrows indicate tones that sound

Part III

INDIAN MUSIC

Ancient Beginnings

≈ 11.20 ≈

One of the oldest and most revered texts on Indian music is a work entitled *Nāṭyaśāstra*, written by Bharata (early centuries A.D.). Although large portions of Bharata's treatise recount performance practices of the theater and dance, Volume 2, Chapters 28–33, deal exclusively with music. In *Nāṭyaśāstra* 28.21, Bharata begins his description of the classical 22-*śruti* scale by giving the names of seven *svaras*, translated below as *notes*, and also interpreted in this discussion as *tones* and *scale degrees*.

Nāṭ. 28.21 — The seven notes [*svaras*] are: *Ṣaḍja* [Sa], *R̥ṣabha* [Ri], *Gāndhāra* [Ga], *Madhyama* [Ma], *Pañcama* [Pa], *Dhaivata* [Dha], and *Niṣāda* [Ni].¹ (Text in brackets mine.)

Bharata then defines the musical qualities of four different kinds of sounds, and specifies the consonant and dissonant intervals contained in two different scales called *Ṣaḍjagrāma* (*Sa-grāma*) and *Madhyamagrāma* (*Ma-grāma*).

Nāṭ. 28.22 — [According] as they relate to an interval of [more or less] *Śrutis*, they are of four classes, such as Sonant (*vādin*), Consonant (*saṃvādin*), Assonant (*anuvādin*), and Dissonant (*vivādin*).

That which is an *Aṃśa* [note] anywhere, will in this connection, be called there Sonant (*vādin*). Those two notes which are at an interval of nine or thirteen *Śrutis* from each other are mutually Consonant (*saṃvādin*), e.g., *Ṣaḍja* and *Madhyama*, *Ṣaḍja* and *Pañcama*, *R̥ṣabha* and *Dhaivata*, *Gāndhāra* and *Niṣāda* in the *Ṣaḍja Grāma*. Such is the case in the *Madhyama Grāma*, except that *Ṣaḍja* and *Pañcama* **are not** Consonant, while *Pañcama* and *R̥ṣabha* **are so** . . .

23 — In the *Madhyama Grāma*, *Pañcama* and *R̥ṣabha* are Consonant while *Ṣaḍja* and *Pañcama* are so in the *Ṣaḍja Grāma* [only].

The notes being at an interval of [two or] twenty *Śrutis* are Dissonant, e.g., *R̥ṣabha* and *Gāndhāra*, *Dhaivata* and *Niṣāda*.

. . . As a note [prominently] sounds it is called Sonant; as it sounds in consonance [with another] it is Consonant; as it sounds discordantly [to another] it is Dissonant, and as it follows [another note] it is called Assonant. These notes become low or high according to the adjustment of the strings . . . of the *Vīṇā* . . .² (Bold italics mine.)

With this general background information — which will prove crucial in constructing the scales — Bharata then quantifies these seven scale degrees according to how many *śrutis* (from the Sanskrit *śru*, lit. *to hear*; *śruti* in music, *an interval*) are contained between each degree.

Nāṭ. 28.23 — . . . Now, there are two *Grāmas*: *Ṣaḍja* and *Madhyama*. Each of these two (lit. there) include twenty-two *Śrutis* in the following manner:

24 — *Śrutis* in the *Ṣaḍja Grāma* are shown as follows: **three** [in Ri], **two** [in Ga], **four** [in Ma], **four** [in Pa], **three** [in Dha], **two** [in Ni], and **four** [in Sa].

In the *Madhyama Grāma*, *Pañcama* should be made deficient in one *Śruti*. The difference which occurs in *Pañcama* when it is raised or lowered by a *Śruti* and when consequential slackness or tenseness [of strings] occurs, will indicate a **typical** (*pramāṇa*) *Śruti*.³ (Bold italics and text in brackets mine.)

Next, Bharata describes a demonstration on two *vīṇās*, each equipped with seven strings, and tuned exactly alike to the *Sa-grāma*. The tuning of one *vīṇā* remains unchanged. Bharata gives directions for changing the tuning of the other *vīṇā* in four separate steps. Each step requires the lowering of all seven degrees by increments of one *śruti*. Consequently, after the first step, or after lowering all the strings by 1 *śruti*, no two degrees of the two *vīṇās* match because the smallest interval of the *Sa-grāma* consists of 2 *śrutis*. After the second step, or after lowering Ga by 2 *śrutis*, it will sound the same tone as Ri of the *unchanged vīṇā*; and after lowering Ni by 2 *śrutis*, it will sound the same tone as Dha of the *unchanged vīṇā*. Similarly, after the third step, or after lowering Ri by 3 *śrutis*, it will sound the same tone as Sa of the *unchanged vīṇā*; and after lowering Dha by 3 *śrutis*, it will sound the same tone as Pa of the *unchanged vīṇā*. Finally, after the fourth step, or after lowering Ma by 4 *śrutis*, it will sound the same tone as Ga of the *unchanged vīṇā*; after lowering Pa by 4 *śrutis*, it will sound the same tone as Ma of the *unchanged vīṇā*; and after lowering Sa by 4 *śrutis*, it will sound the same tone as Ni of the *unchanged vīṇā*. In a passage translated by N.A. Jairazbhoy,⁴ Bharata states, “. . . lower again, in exactly this manner . . .” (*punarapi tad-vadevapakarṣāt*),⁵ which means that this experiment was intended to prove that all *śruti* intervals are exactly equal in size. Bharata implies that *only* controlled decreases by identical *śrutis* will produce the scale degrees on the changed *vīṇā* that exactly match the degrees of the *unchanged vīṇā*. In this context, the *unchanged vīṇā* represents a scientific control, or an aural reminder of the *unchanged vīṇā* before it was lowered.

Bharata then summarizes

Nāṭ. 28.25–26 — In the *Ṣaḍja Grāma*, *Ṣaḍja* includes four *Śrutis*, *Rṣabha* three, *Gāndhāra* two, *Madhyama* four, *Pañcama* four, *Dhaivata* three, and *Niṣāda* two.

27–28 — [In the *Madhyama Grāma*] *Madhyama* consists of four *Śrutis*, *Pañcama* three, *Dhaivata* four, *Niṣāda* two, *Ṣaḍja* four, *Rṣabha* three, and *Gāndhāra* two *Śrutis*. [Thus] the system of [mutual] intervals (*antara*) has been explained.⁶

In the absence of clearly defined length ratios and interval ratios,⁷ this mixture of numerical and verbal terms seems completely open to interpretation. However, a historically accurate analysis reveals that the musical possibilities contained in this text are extremely limited and point toward only one plausible explanation. Before we examine this interpretation of Bharata’s text, let us first eliminate two possibilities.

In *Nāṭyaśāstra 28.24*, Bharata distinguishes between the *Sa-grāma* and the *Ma-grāma* by stating that in the former scale, Pa contains 4 *śrutis*, and in the latter scale, Pa contains only 3 *śrutis*. He defines this difference based on a *typical śruti*, or a *pramāṇa śruti*. Bharata goes on to describe his experiment with two *vīṇās*, which only works if the *pramāṇa śruti* is a standard interval, or an interval of a constant size. All these formulations lead to one possibility, namely, that Bharata was contemplating *geometric division* of the “octave” into 22 equal parts. To achieve such a “division”

Part IV

ARABIAN, PERSIAN, AND TURKISH MUSIC

≈ 11.45 ≈

North American musicians who do not read Arabic, French, or German have very limited opportunities to study ancient Arabian music and tuning theory from original sources. Of the treatises on music written by Al-Fārābī (d. *c.* 950), Ibn Sīnā (980–1037), Ṣafī Al-Dīn (d. 1294), Al-Jurjānī (d. 1413), Al-Lādhīqī (d. 1494), and Al-Shirwānī (d. 1626), not a single work has ever been translated into English. Furthermore, due to intractable religious, linguistic, and intellectual prejudices against Islam, Christian-dominated institutions throughout Europe — such as Catholic and Protestant churches, schools and universities, and the craft guilds — managed by 1600 to completely eradicate the Arabian influence from the written history of European music. For example, the works of Michael Praetorius (1571–1621) and Marin Mersenne (1588–1648) offer no information on the origins of one of the most important instruments of their time: the lute. First in Arabian history (from approximately 700) and later in European history (to approximately 1700), the fretted lute served for a thousand years as an instrument of scientific exploration and musical expression. Henry George Farmer (1882–1965), an eminent historian of Arabian music, gives this etymology of lute (from the Arabic *al-'ūd*, *the lute*; lit. *flexible stick* or *branch*):

Western Europe owes both the instrument and its name to the Arabic *al-'ūd*, as we see in the Portuguese *alaud*, the Spanish *laud*, the German *Laute*, the Dutch *Luit*, the Danish *Lut*, the Italian *liuto*, the English *lute*, and the French *luth*.¹

Are we to naïvely accept the highly improbable possibility that while Europeans inherited the lute from the Arabs, European musicians learned absolutely nothing about tuning from Arabian musicians? Consider the following fact: by the end of the 13th century, Arabian literature included not only a voluminous and highly sophisticated collection of works on the art and science of music, but on the precise mathematics of lute tunings as well.

Between approximately A.D. 750 and 1250, many nations in the West experienced the religious, scientific, and artistic influences of what I call the Arabian Renaissance. After the life and death of the prophet Mohammed (*c.* 570 – d. 632), a stunning series of military campaigns brought Spain, Sicily, North Africa, Egypt, Syria, al-'Iraq, Persia (modern Iran), Farghānah (Central Asia), Ṭukhāristān (modern Afghanistan), and Western India (modern Pakistan) under Moslem control. Coincidentally, most of these territories were conquered by Alexander the Great (356–323 B.C.) a thousand years earlier. To administer their newly conquered empire, Moslem rulers created two great cultural centers. In 762 Baghdād became the capital of the empire in the east, and subsequent to the invasion of 711 into Spain, in 756 Cordova became the capital of the empire in the west. The former was destroyed by Mongols in 1258, and the latter, reconquered by Christians in 1236. The *Reconquista* (Reconquest) of Spain continued until the final defeat of the Moslems at Granada in 1492.²

Reminiscent of the building of Alexandria by Alexander the Great, Baghdād and Cordova boasted running water, paved and lighted streets, world-renowned architectural monuments, international markets, universities, hospitals, and above all, libraries that contained hundreds of thousands of volumes. If it were not for these libraries, and the care Arabian translators and scholars bestowed on ancient texts, the works of Homer, Hippocrates, Plato, Aristotle, Euclid, Archimedes, Nicomachus, and Ptolemy, to name only a few, would probably not have survived. The task of

translating these volumes began in Baghdād in approximately 750, and later became centralized at the famous Bayt al-Ḥikmah (House of Wisdom) in 830. By the end of the 10th century, most of the translations were completed. This phenomenal achievement raises the inevitable question, “Is the Italian Renaissance indebted to the Arabian Renaissance?” To contemplate the profound interdependence of these two civilizations, consider this biographical account from Philip K. Hitti’s exhaustive work entitled *History of the Arabs*:

Al-Kindi . . . flourished in Baghdād. His pure Arabian descent earned him the title “the philosopher of the Arabs,” and indeed he was the first and last example of an Aristotelian student in the Eastern caliphate who sprang from Arabian stock. Eclectic in his system, Al-Kindi endeavored in Neo-Platonic fashion to combine the views of Plato and Aristotle and regarded the Neo-Pythagorean mathematics as the basis of all science. Al-Kindi was more than a philosopher. He was astrologer, alchemist, optician and music theorist. No less than two hundred and sixty-five works are ascribed to him, but most of them unhappily have been lost. His principal work on geometrical and physiological optics, based on the *Optics* of Euclid in Theon’s recension, was widely used in both East and West until superseded by the greater work of ibn-al-Haytham [d. c. 1039]. In its Latin translation, *De aspectibus*, it influenced Roger Bacon [c. 1214 – d. 1292]. Al-Kindi’s three or four treatises on the theory of music are the earliest extant works in Arabic showing the influence of Greek writers on that subject. In one of these treatises Al-Kindi describes rhythm (*īqā’*) as a constituent part of Arabic music. Measured song, or mensural music, must therefore have been known to the Moslems centuries before it was introduced into Christian Europe. Of Al-Kindi’s writings more have survived in Latin translations, including those of Gerard of Cremona [d. 1187], than in the Arabic original.³ (Dates in brackets mine.)

≈ 11.46 ≈

The oldest extant source on Arabian music is a work entitled *Risāla fī hubr tā’līf al-alḥān* (On the composition of melodies), by Ishāq Al-Kindī (d. c. 874). Because this text only survived as a fragmented 17th-century transcription of a 13th-century copy, many pages are missing; this explains why the text begins in mid-sentence. Fortunately, the fragments provide enough information to impart Al-Kindī’s *’ūd* tuning, which bestows the following six incipient contributions on the history of music:

(1) Outside China, this is the first mathematical description of a 12-tone chromatic scale. Although Al-Kindī’s scale also consists of a spiral of “fifths,” it differs from the Chinese model in that the tonic, ratio $\frac{1}{1}$, simultaneously functions as the origin of two different spirals: one ascends four “fifths,” or four $\frac{3}{2}$ ’s, and the other descends seven “fifths,” or seven $\frac{3}{2}$ ’s. (See Section 11.47, Table 11.22.)

(2) Al-Kindī’s 12-tone scale is the first tuning that uses identical note names to identify the tones of the lower and upper “octave.” In his text, Al-Kindī specifically states that the musical *qualities* of tones separated by an “octave” are identical.

(3) This is the first mathematically verifiable scale that accounts for the comma of Pythagoras. In his *’ūd* tuning, Al-Kindī distinguishes between the *apotome* [C♯], ratio $\frac{2187}{2048}$, and the *limma* [Db], ratio $\frac{256}{243}$.

12 / ORIGINAL INSTRUMENTS

Acoustic music is the most difficult music. Building musical instruments from the ground up is an expression of freedom and, therefore, an expression of imagination. Nothing about this art is hewn in stone. The creative builder examines all aspects of musical instrument construction, and on a case-by-case basis decides which traditions to keep, and which to throw out.

I build because the tunings and timbres I want to hear do not exist on store shelves. Robinson Crusoe built because he had no choice. And yet, his creations also had no critics, and so his imagination became his life. Often when I hike through forests or climb mountains, I am reminded that only man knows what time it is. When I enter Crusoe's world, or when in building an instrument time ceases to exist, I live with the knowledge that success is only a function of thought, work, and patience.

The desire for perfection is the juggernaut of creativity. All my instruments are flawed. A bar may not ring as long as another bar; a canon bridge may be too high or too low; or a tone hole may be too wide or too narrow. I know where all the flaws are, and could find many more. But what is the point? The only thing that matters is to build and to make a music that is sustainable in time. I was born a musician, and have built musical instruments since 1975. In the words of Walt Whitman (1819–1892), “I . . . begin, hoping to cease not till death.”

I also hope that this book and Chapters 12–13 will inspire others to think critically about acoustic music, and perhaps to build an original instrument or two. One of the happiest moments of my life is to finish a project, step back, and declare in a state of complete surprise, “I'd like to meet the person who built this instrument.”

Stringed Instruments

CHRYSALIS

≈ 12.1 ≈

The Chrysalis in Plate 1, my first concert-size instrument, was inspired by a large, round, stone-hewn Aztec calendar. I asked myself, “What if there was a musical instrument in the shape of a wheel? And what if this wheel had strings for spokes, could spin, and when played, would sound like the wind?” As described below, the Chrysalis wheel has two sides, or two circular soundboards, covered by eighty-two strings on each side.

Figure 12.1(A) shows that a steel axle (a) passes through the center of an octagonal oak hub (b). This hub acts as the central structural component of the wheel. Eight birch spokes (c) radiate from the hub to the centers of eight maple dowel spacers (d), which in turn hold two birch plywood rings (e). Figure 12.1(B) illustrates two Sitka spruce soundboards (f) glued to the rings. The rings

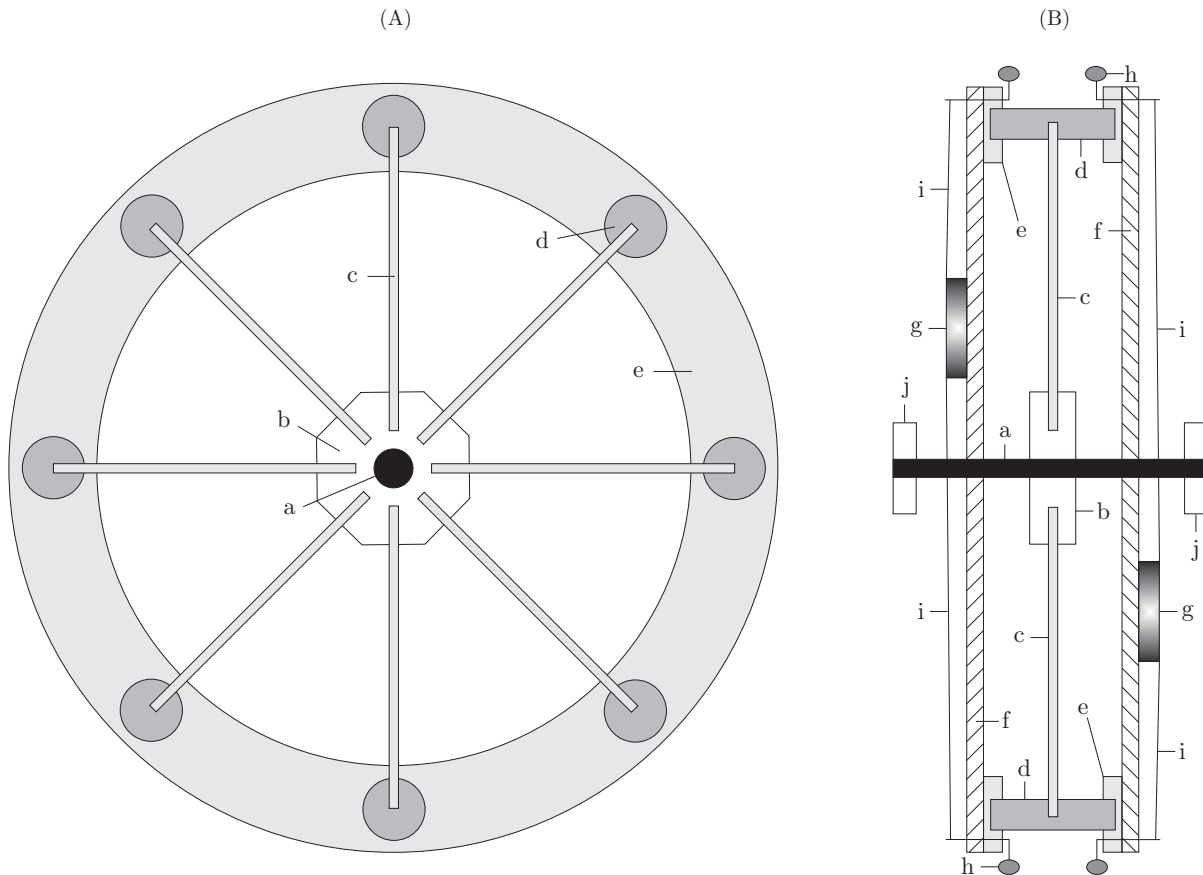

Figure 12.1 Parts and construction of the Chrysalis wheel. (A) This longitudinal cross-section shows a steel axle (a) that passes through the center of an octagonal hub (b). This hub acts as the central structural component of the wheel. Eight spokes (c) radiate from the hub to the centers of eight dowel spacers (d), which in turn hold two plywood rings (e). (B) This transverse cross-section illustrates two soundboards (f) glued to the rings, and two aluminum bridges (g) fastened to the soundboards. Tuning gears (h) encircle both soundboards. From here, long and short steel strings (i) pass to the bridges. Two sealed ball bearings (j) support the wheel at the ends of the steel axle. These bearings enable the performer to turn the wheel in either direction. (Not to scale.)

reinforce the edges of the soundboards while leaving the inner soundboard surface areas unobstructed for maximum resonance. The soundboards consist of several jointed strips of spruce 6.0 in. wide by $\frac{1}{4}$ in. thick. On the back sides, spruce ribs glued against the grain give the soundboards structural support. Furthermore, two bridges (g) fastened at off-center locations on the soundboards provide the instrument with varying string lengths. The original rosewood bridges exploded from the force of the strings; so, I replaced them with aluminum bridges. I located the bridges directly opposite each other, which enables the performer to reach both long and short strings from the playing position to the left of the wheel; this configuration of the bridges also balances the motion of the wheel. Eighty-two tuning gears (h) encircle each soundboard. From here, steel strings (i) pass to the bridges. Note that the two longest strings go through holes in the axle. Two sealed ball bearings (j) support the wheel at the ends of the axle. These bearings enable the performer to turn the wheel in either direction. Finally, the wave-like stand — inspired by my love of the ocean and many years of surfing along the coasts of California and Mexico — affords maximum access to the strings; at any given position of the wheel, all but a few strings are within reach of the performer.

13 / BUILDING A LITTLE CANON

Parts, Materials, Labor, and Detailed Dimensions

The Little Canon in Plate 12 is the first musical instrument I built. Since a small canon is not too difficult to make, the following description may inspire some readers to build such an instrument, and to verify for themselves which intervals and scales sound consonant, and which sound dissonant.

The Little Canon consists of a long rectangular sound box equipped with six strings. Figure 13.1 shows a transverse cross-section of the sound box. The top or soundboard (a) and two sides (b) are redwood. Clear kiln-dried redwood is fairly resonant and, in Northern California, is easily obtained in many different dimensions. However, Sitka spruce works just as well, and produces a better tone. The base (c) is birch plywood. Plate 12 does not reveal the layers of the plywood base because I veneered the exterior edge with birch veneer. A rigid base is very important because it prevents the instrument from bending and twisting out of shape after the strings are tensioned. Also in Figure 13.1, note that the top and base overlap the side pieces. This design ensures that the top and base provide flat gluing surfaces. Now, in the corners along the entire lengths of the top and side pieces, and along the entire lengths of the base and side pieces, redwood liners (d) reinforce the sound box joints and strengthen the instrument as a whole. First, I glued the upper and lower liners to the sides. Next, I used flat head wood screws (e) and glue to secure the base to the sides. Finally, I fastened the top to the sides.

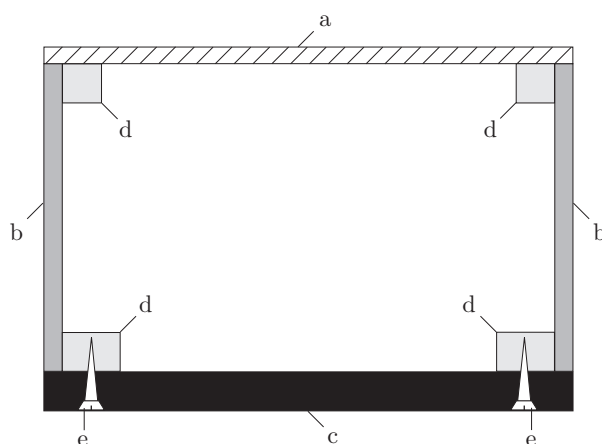

Figure 13.1 Parts and construction of the sound box of the Little Canon. This transverse cross-section shows that redwood top (a) and birch plywood base (c) overlap the redwood sides (b). Redwood liners (d), glued into the corners along the lengths of the top and side pieces, and along the lengths of the base and side pieces, reinforce the sound box joints. Flat head wood screws (e) secure the base to the sides.

Turn to Figure 13.2, which shows a longitudinal cross-section of the Little Canon. To close the structure, notice that I glued redwood end pieces (a) to the top and sides at the ends of the sound box. However, observe carefully that the plywood base (b) extends beyond the two end pieces. Flat head wood screws secure a rounded beech hitch block (c) to the base at the right end, and a short angled birch block (d) to the base at the left end of the instrument. I also glued these two blocks to the end pieces. Plate 12 shows that the hitch block on the right has six holes for threading and fastening the ends of the strings. The angled block on the left supports a birch tuning gear bracket (e). Four oval head wood screws secure the tuning gear bracket to the angled block. Also, note that I cut two long slots into the bracket. I then drilled three holes that pass through the front edge, the front slot, and into the body of the bracket; similarly, three holes pass through the back edge, the back slot, and into the body of the bracket. Next, I inserted three nylon posts of a tuning gear assembly (f) through the front holes, and three nylon posts of a tuning gear assembly through the back holes. Four screws hold each assembly in place. Three strings enter each slot and wind around the nylon posts to tension the strings.

Plate 12 and Figure 13.2 show that a birch nut (g) and a stationary maple bridge (h) support six strings (i). The nut and bridge have hard rosewood caps to prevent the strings from cutting into these parts. I glued the nut into an angled slot in the tuning gear bracket and against the left end piece; and I epoxied the bridge on the top near the hitch block. Both components have a height of $\frac{7}{8}$ in. above the redwood top or soundboard so that the strings run parallel to the surface of the soundboard. Finally, six moveable oak bridges (j) divide the strings into different vibrating lengths.

With respect to materials, there are two basic kinds of wood: softwoods and hardwoods. Spruce and redwood are domestic softwoods; birch, beech, maple, and oak are domestic hardwoods. Rosewood is a tropical hardwood with a weight density greater than water, which means it does not float. (See Appendices E and G.) For the sound box and liners, it is important to use clear kiln-dried redwood or spruce. However, for the rest of the instrument, all domestic hardwoods work equally well. I used five different hardwoods simply because they were available to me.

I strongly recommend yellow woodworking glue called aliphatic resin glue, and two-part clear epoxy. Do not use white glue or hide glue. Also, I no longer use wood screws. The tapered shanks and shallow threads of these screws do not cut into the fibers of the wood very well. Instead, I use sheet metal screws (also called tapping screws) in wood. These screws have cylindrical shanks and extremely sharp and deep threads.

The lengths of commercial acoustic guitar strings determine the distance of the Little Canon from the farthest tuning gear posts to the hitch block. Since this instrument requires six identical strings, one must buy six identical sets of guitar strings because all the strings in a single set have different diameters. Readers interested in building large canons with long strings must make their own strings. Piano supply houses and some local piano technicians sell high-carbon spring steel music wire in 1 lb. rolls. However, piano wires do not work for making canon strings because the diameters are too thick and, therefore, require too much tension to produce a good tone. See Appendix D for ordering thin steel music wire sizes with diameters in the 0.016–0.024 in. range. Also, tuning gears equipped with long nylon posts are available from local guitar shops.

Readers who would like to own a small canon but are not inclined to build one must hire a woodworker. A professional should require approximately 10 hours to build such an instrument. The sound box is the most time-consuming task. First, thick boards must be either resawn or surface planed to make the thin top, side, and end pieces. Then the liners must be glued to the inside surfaces of the sides before the sound box can be assembled. While the glue is drying, all the other parts can be made. To minimize labor charges, the reader should have the tuning gears and strings available for measuring before the building begins.

We hope you have enjoyed this preview.

[Buy Now](#)